



FINAL REPORT

Greenhouse Gas Reduction Fund

LCTI: California Collaborative Advanced Technology Drayage
Truck Demonstration Project

CARB Grant #G14-LCTI-09



Table of Contents

Executive Summary

BYD Motors Final Report

Peterbilt GGRF Final Project Report

Kenworth Near Zero Emission Drayage Truck Demonstration Project

Volvo Project Ultra Final Report

California Collaborative Advanced Technology Drayage Truck Demonstration Project

Class 8 heavy-duty on road trucks used to transport cargo to or from California's ports and intermodal rail yards comprise this portfolio of commercially promising zero and near-zero emission truck technologies. These trucks demonstrate the practicality and economic viability of zero and near-zero emission technology operating in revenue service in and around the Ports of Long Beach, Los Angeles, Oakland, Stockton and San Diego. In part of this project, installation of charging infrastructure will enable safe charging of the trucks for statewide demonstration. The project has four original equipment manufacturers (OEMs) participating: BYD Motors, Kenworth Truck Company, Peterbilt Motors and Volvo Technology of America, LLC.

This project provides development and commercialization of zero- and near-zero emission trucks by building upon the success of recent truck demonstration projects. Phase 1 deployment included trucks with previously developed technologies, such as Kenworth's CNG range extended plug-in hybrid electric trucks developed under the ZECT 2 program and Volvo's diesel plug-in hybrid electric truck developed under a DOE grant. In Phase 2, OEMs supported larger deployments with various innovations.

Project partners include Bay Area AQMD, San Diego APCD, San Joaquin Valley APCD, San Diego G&E, University of California Riverside, West Virginia University, LA Metro, 23 demonstration fleets and technology partners.

44 pre-commercial and commercial Class 8 zero- and near-zero emission drayage trucks and infrastructure were deployed into fleets:

- 25 BYD battery electric trucks with 100 – 124 mile electric range
- 12 Peterbilt/Meritor battery electric trucks with 100-150 mile electric range
- 2 Kenworth CNG range extended plug-in hybrid electric trucks with a 50 EV & 200 mile HEV range
- 3 Volvo diesel plug-in hybrid electric trucks with 30 mile electric/400 mile range and 2 battery electric trucks with 150 mile electric range

The 23 end-user fleets for the GGRF ZEDT project are: GSC Logistics, Pasha Distribution, Sea-Logix (Pasha), Quik Pick Express, Total Transportation Systems Incorporated, AJR/MBD Trucking, 4Gen Logistics, Golden State Express, PepsiCo/New Bern, Estes Express, Harris Ranch, NFI, Biagi Brothers, Oak Harbor, Werner, Daylight, Anheuser Busch, BAE Systems Ship Repair, Southern California Edison, Los Angeles Department of Water and Power, Benore Logistics, IBT, and Producers Dairy.

In addition, a portion of funding from the GGRF ZEDT project also engaged CALSTART, Achates Power Inc.(API), Southwest Research Institute (SwRI), Eberspaecher, and South Coast AQMD to support durability testing of a low NO_x capable opposed piston engine. The GGRF ZEDT project funded work in Tasks 8.1 and 8.2 includes completion of an aging protocol for use on an aftertreatment (AT) system for up to 435,000 miles. Subsequent work on this project will continue with funding from South Coast AQMD through its Clean Fuels Fund (31) as part of an opposed piston engine Class 8 demonstration which will deploy and validate an engine design that will meet a near-zero NO_x requirement (0.02 g/bhp-hr), while simultaneously providing a 15-20% increase in fuel efficiency compared to 2017 EPA requirements. This will be the first demonstration in the United States of a high-efficiency and low NO_x engine powertrain vehicle in Class 7-8 applications. API will develop four 10.6L OP engines, including three aftertreatment systems, and install them into one Class 8 trucks provided by Peterbilt. Peterbilt will also perform integration services and support and perform vehicle calibration and testing. Subsequently, the trucks will be placed in revenue service with Walmart for a minimum of three months as part of the field demonstration, including the use of renewable diesel. The overall goal of the project is to realize near- and long-term certification and commercialization goals and establish higher efficiency, near-zero emission, liquid fueled engines as an industry standard.

Since the GGRF ZEDT project started in 2016, there has been a significant evolution in zero and near-zero Class 8 truck technologies. BYD, Peterbilt, Volvo and other OEMs outside of this project now have CARB certified battery electric trucks available for sale to fleets in California. Near-zero emission Class 8 truck technologies such as recent engine developments for ultralow NO_x engines meeting a .02g/bhp-hr emission standard are also creating more near-zero emission truck technologies in addition to Kenworth's CNG hybrid electric truck and Volvo's diesel

hybrid electric truck. The work to support durability testing and demonstration of a low NOx opposed piston engine to realize near-term certification, commercialization, and establishment of a higher efficiency, near-zero emission standard for liquid fueled engines could result in additional technology breakthroughs for Class 8 near-zero emission trucks.

Over the years, there have been many lessons learned in the GGRF ZEDT project, with different challenges that have been overcome by the OEMs.

- BYD: Challenges in previous trucks such as compatibility issues with truck and vehicle telematics software; better battery pack software management; moving away from proprietary to standard CCS1 charging connectors starting with the Gen 2 truck configuration; rewiring power to the lift gate for beverage delivery. These issues were addressed in future versions of the truck.
- Kenworth: Supply chain issues and other challenges with creating hybrid electric trucks indicating that commercial vehicle supply chain not ready to produce and support hybrid electric trucks at volume. Continued refinement of hybrid electric drivetrain to operate in all electric and hybrid electric modes.
- Peterbilt: Managing charging rates, infrastructure costs, different range and efficiency depending on duty cycles by fleets; faster onboard charging and energy storage design.
- Volvo: Refinement of two proven technologies for seamless operation, further validation and design consideration of PHEV battery/engine interface, continuing evaluation of battery management systems for robustness



**California Greenhouse Gas Reduction
Fund (GGRF) Zero Emission Drayage
Truck (ZEDT) Demonstration
G14-LCTI-09**

BYD Motors Final Report



EXECUTIVE SUMMARY	3
TASK 2.1 PRODUCT TESTING AND REGISTRATION	4
TASK 2.2 EVSE INSTALLATION AND DATA COLLECTION	5
A. EVSE INSTALLATION.....	6
B. DATA COLLECTION	6
TASK 2.3 TRUCK PRODUCTION FOR PHASE 1	7
A. SPECIFICATIONS.....	7
B. CERTIFICATIONS.....	8
TASK 2.4 FLEET REGISTRATION PHASE 1 AND INTEGRATION INTO FLEETS	8
TASK 2.5 PHASE 1 FIELD DEMONSTRATION	9
A. GSC LOGISTICS	9
B. TOTAL TRANSPORTATION SERVICES	9
C. AJR TRUCKING	10
TASK 2.6 PHASE 1 TRUCK REWORK	10
TASK 2.7 CONTINUED DEMONSTRATION OF PHASE 1 TRUCKS.....	11
TASK 2.8 BEGIN TRUCK PRODUCTION FOR PHASE 2	11
A. SPECIFICATIONS.....	12
B. CERTIFICATIONS.....	12
TASK 2.9 FLEET REGISTRATION PHASE 2 AND INTEGRATION INTO FLEETS	14
TASK 2.10 PHASE 2 DEMONSTRATION.....	15
A. GOLDEN STATE LOGISTICS AND QUIK PICK EXPRESS.....	15
B. 4GEN LOGISTICS	16
C. SEA-LOGIX.....	16
D. TOTAL TRANSPORTATION SOLUTIONS.....	17
E. PASHA DISTRIBUTION SERVICES	17
F. ANHEUSER BUSCH.....	17
TASK 2.11 PROJECT REPORTING	18
TASK 2.12 MARKET ASSESSMENT DRAFT AND FINAL MARKET ASSESSMENT	18

Executive Summary

CARB Greenhouse Gas Reduction Fund (GGRF) Zero Emission Drayage Truck Demonstration Project (ZEDT) is funded through a FY 2014-15 grant for the Air Quality Improvement Program and Low Carbon Transportation Greenhouse Gas Reduction Fund Investments. The GGRF ZEDT project is part of California Climate Investments (CCI), a statewide initiative that puts billions of Cap-and-Trade dollars to work reducing greenhouse gas emissions, strengthening the economy, and improving public health and the environment – particularly in disadvantaged communities. The GGRF ZEDT project is funded through CARB grant G14-LCTI-09 to deploy 44 pre-commercial zero and near-zero emission Class 8 battery electric, CNG and diesel hybrid electric drayage trucks along with supporting infrastructure will be operated in revenue service throughout the state at the Ports of Los Angeles, Long Beach, San Diego and Oakland in the South Coast AQMD, Bay Area AQMD, San Joaquin Valley APCD, and San Diego APCD jurisdictions. There are four participating OEMs – BYD, Kenworth, Peterbilt/Meritor/TransPower, and Volvo.

BYD Motors LLC (BYD) is a US manufacturing company based in Los Angeles, CA with a 550,000 square foot manufacturing plant in Lancaster, CA. BYD is a wholly owned subsidiary of BYD Company Ltd, a global heavy equipment manufacturer. BYD was founded in 1995 as an advanced battery manufacturer and consumer electronics company. BYD continues as a leading manufacturer of smart phones, tablets, and laptops for global partners such as Apple, Dell, Toshiba, Microsoft, Samsung, Motorola, and many more.

Through these efforts, BYD has become one of the world's largest producers of rechargeable batteries, driving innovation by reinvesting billions of US dollars into research and development. In 2003, BYD entered the automotive market and began to apply its battery expertise to the transportation industry, becoming the largest electric car manufacturer in the world. Over these past 20 years, BYD has delivered more electric vehicles than any other automaker in the world with the BYD Commercial Vehicles Group having delivered over 70,000 Electric Buses, and more than 17,000 Electric Trucks.

The 550,000 square foot BYD Lancaster Factory supports R&D and assembly for BYD's 100% battery electric medium- and heavy-duty trucks, including the BYD 8T. The 100,000 square foot warehouse serves as the North America Parts and Components Distribution Center. Through operations in this facility, BYD is leading the electric commercial vehicle market in the United States, with over 600 all-electric buses and 200 all-electric trucks already delivered.

Task 2.1 Product Testing and Registration



Figure 1 - BYD Phase 1 8TT in service at GSC Logistics in Oakland.

The truck produced for this project is the BYD 8TT, shown in revenue service at GSC Logistics in Oakland in Figure 1 above. The 8TT is an over-the-road tractor designed to be operated in shorter-haul and drayage applications. At the time of application for this project, the 8TT was still in the design phase, built upon then-current prototypes and BYD's experience in manufacturing other battery electric vehicles ranging from urban delivery (Class 2-5), buses, and municipal trucks. More specifically, BYD integrated several of its core competencies into the 8TT:

- Innovation:
 - Batteries: The batteries are proprietary iron phosphate (Fe) batteries that were purpose-built for transportation. Fe batteries have three distinct advantages relative to competitive technologies:
 - Long-lasting: retain 70% charge after 10,000 cycles compared to other lithium ion batteries that tend to degrade more rapidly.
 - Safe: BYD's battery chemistry is focused on safety. Cell reactions are not exothermic, making it highly unlikely to overheat or catch fire.
 - Environmentally-friendly: primary components in BYD's Fe batteries are iron and phosphate with non-toxic electrolytes rather than heavy metals and toxic electrolytes.

- Motors: Traction motors used on the 8TT are in-line traction motors, meaning they are integrated into the rear axles. The two motors are able to provide a combined 402 hp and 1,475 ft-lb of torque.
- Safety:
 - BYD batteries: The Fe cells are designed with vents to force heat out to avoid hotspots. Laser welds are used to connect each cell, reducing heat generation. High voltage packs are segmented into lower voltage connections, providing safer handling during production, maintenance, or accidents. The modules also have flame retardant polymer coatings and protective covers for critical areas. If any issues are detected, the battery management system (BMS) disconnects the contactors to isolate problem areas.
 - A maintenance switch disconnects the batteries and distribution box to avoid shocks or hazards.

Task 2.2 EVSE Installation and Data Collection

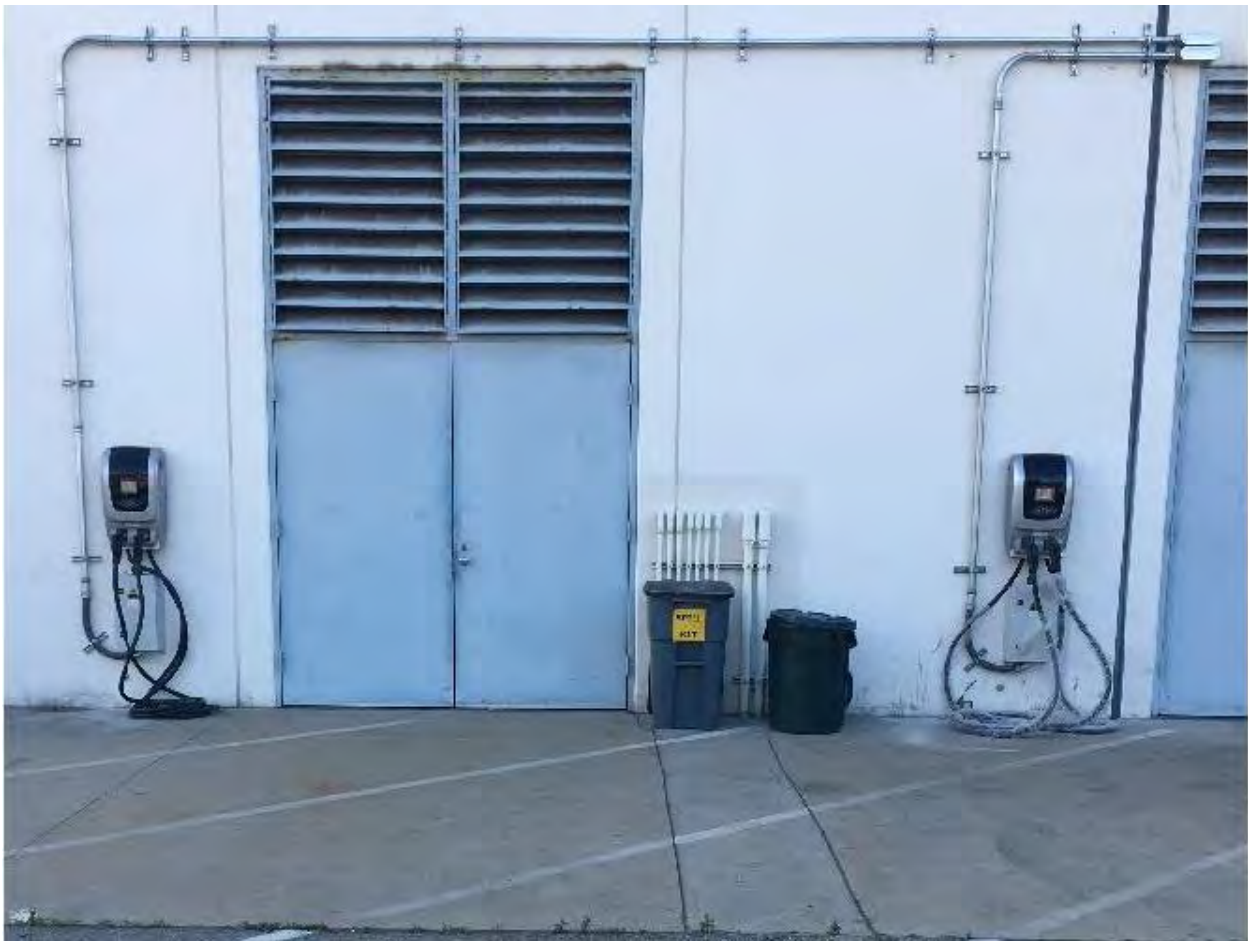

Figure 2 - BYD 80kW chargers installed at Total Transportation Services (TTSI) in San Pedro.

A. EVSE Installation

Electric vehicle supply equipment (EVSE) deployed with the Phase 1 and Phase 2 trucks are BYD 80kW AC and BYD 40kW AC chargers respectively. Chargers for Phase 2 trucks are lower power than Phase 1 truck chargers because BYD changed the charging platform to meet the demands and trends of the medium and heavy duty vehicle (MHDV) market. At TTSI in San Pedro, BYD 80 kW AC chargers were installed for the four trucks deployed at this fleet, as shown above in Figure 2.



Figure 3 - IEC62196-2-type Charging Gun

The BYD AC charging coupler is based on the IEC62196-2 standard shown above in Figure 3, commonly seen in Europe and China, but not in the U.S. What this meant in practice for US deployments is that these chargers can only be used on BYD trucks and are not compatible with other battery electric trucks in the US. Despite this limitation, for this project these chargers provided two large benefits to customers and the timeline for the project. The primary benefit of these chargers is that they are relatively high powered chargers at a relatively low cost. A similarly sized 40kW or 80kW DC charger would be orders of magnitude more expensive than the BYD AC charger. Another benefit of these chargers is the relatively straight forward nature of the installation of the chargers. These chargers are small, lightweight, and can be mounted on various structures, including affixing them straight into the wall of the facility. As long as there is sufficient power, the charger can be installed and conduit run to it without trenching or heavy construction. This simplicity of installation took several months off the required installation time for each fleet.

There are also some challenges to deploying these chargers, primarily in the form of the wiring configuration – three wire vs. four wire – with the primary difference being the former combines the Ground and Neutral wires while the latter separates them into two separate wires. Three wire 480V power is very common for industrial installations in the U.S. BYD’s chargers use the four-wire configuration, meaning that some end users encountered additional costs and time requirements to upgrade transformers and related electrical equipment. These additional costs and time requirements are still generally lower than for DC chargers.

B. Data Collection

A significant amount of qualitative and quantitative data was collected throughout this project. From the qualitative side, BYD was tasked with providing quarterly progress reports that detailed the progress made and problems encountered each quarter. Quarterly maintenance reports provided in spreadsheet form identified the trucks that required maintenance during the most recent quarter and relevant related details like the problem identified and the repair work done.

In addition, BYD collected significant quantitative data, in the form of monthly odometer readings from fleets. At the end of each month, BYD would reach out to fleets requesting that they submit odometer readings for each truck. This data was then collated into a spreadsheet and provided to South Coast AQMD. This was done every month. As of December 31, 2021, the 25 trucks had accumulated 293,714 miles in real-world drayage operations.

Detailed operational data, including vehicle performance data, was obtained by HEM using HEM data loggers which was stored, collected, and analyzed by Ricardo. These HEM data loggers were designated for use in this project by CARB. For detailed information regarding this data, please review to Ricardo’s quarterly data collection reports for this project.

Task 2.3 Truck Production for Phase 1

Based on the above technical innovations, the Phase 1 trucks were designed and manufactured in BYD’s facilities in China. The trucks were produced to the following specifications as shown in Table 1 below.

A. Specifications

Table 1 – BYD Phase 1 Battery Electric Truck Specifications

Chassis	BYD 8TT Phase 1
Length	286.8 in.
Width	98.4 in.
Height	121.5 in.
Wheelbase	160 in.
Curb Weight	23,149 lbs.
GCWR	105,000 lbs.
Top Speed	56 mph
Max Gradeability	20%
Range	100 miles
Wheel Rim	8.25x22.5
Tires	11R22.5
Suspension	Front: Leaf Spring, Rear: Leaf Spring
Brakes	Front: Air Disc, Rear: Air Drum
Max Power	402 hp
Max Torque	1,475 ft. lbs.
Initial Battery Capacity	207 kWh
Charging Power	AC 80 kW
Charging Time	3 hours AC

B. Certifications

The Phase 1 trucks were designed and manufactured in BYD’s facilities in China. The trucks were produced to the following certifications as shown in Table 2 below.

Table 2 – BYD Phase 1 Battery Electric Truck Safety Certifications

Federal Motor Vehicle Safety Standards (FMVSS)	Test Name
101	Controls and Displays
102	Transmission Shift Position Sequence, Starter Interlock, and Transmission Braking Effect
103	Windshield Defrosting and Defogging Systems
104	Windshield Wiping and Washing System
106	Brake Hoses
108	Lamps, Reflective Devices, and Assoc. Equip.
111	Rear Visibility
113	Hood Latch System
119	New Pneumatic Tires for Motor Vehicles with a Gross Vehicle Weight Rating (GVWR) of more than 10,000 lbs.
120	Tire Selection and Rims and Trailer Load Carrying Capacity Information for Motor Vehicles with GVWR > 10,000 lbs.
121	Air Brake Systems
124	Accelerator Control Systems
125	Warning Devices
205	Glazing Materials
207	Seating Systems
208	Occupant Crash Protection
209	Seat Belt Assemblies
210	Seat Belt Assembly Anchorages
302	Flammability of Interior Materials

Task 2.4 Fleet Registration Phase 1 and Integration into Fleets

All necessary registration documents were provided to the fleets, including the weight slip, the Manufacturers Certificate of Origin, and the VIN verification. A half-day of operator training at each fleet primarily involved a familiarization with the start sequence and testing different chassis connections for compatibility, in addition to charging protocol. All fleets ultimately added the trucks to their Port Drayage

Truck Registry where applicable. A detailed list of the Phase 1 truck deployments is presented below in Table 3.

Table 3 – BYD Phase 1 Deployments

PHASE 1					
End User	Address	VIN	Deployment Area	EVSE	
				Qty	Charger Power
GSC Logistics	555 Maritime St. Oakland CA 94607	LA9TYDE8XH1LC0027	Port of Oakland	1	80 kW
TTSI	300 Ferry Street San Pedro CA 90731	LA9TYDE80H1LC0022 LA9TYDE89H1LC0023	Port of Long Beach	2	80 kW
AJR Trucking	435 E Weber Ave Compton CA 90222	LA9TYDE84H1LC0024 LA9TYDE89H1LC0026	Port of Long Beach	2	80 kW

Task 2.5 Phase 1 Field Demonstration

Three logistics companies were selected for operating the Phase 1 trucks – GSC Logistics (GSC) in Oakland, Total Transportation Services (TTSI) in San Pedro, and AJR Trucking (AJR) in Compton. Although the Phase 1 trucks initially had some success in operation, for the most part, they ended up not providing a significant amount of data and did not accumulate many miles. They did, however, provide valuable insights to all parties into things that can go wrong when deploying new technologies and informed the design of the Phase 2 truck for the GGRF ZEDT project.

A. GSC Logistics

In November 2017, GSC became the first end user to receive a BYD Phase 1 8TT as part of this program. GSC was able to provide the most successful demonstration of the Phase 1 trucks, accumulating 16,261 miles operating in and around the Port of Oakland. The primary issue with operating this truck was that the registration was maintained in BYD’s name. This caused a few delays in re-registration due to mail issues BYD encountered during the COVID pandemic in 2020.

B. Total Transportation Services

The TTSI and AJR trucks were much less successful in operation for a variety of reasons. First, the trucks were limited in range, meaning that TTSI, which operates two shifts, could only use one truck for each shift rather than using one diesel truck across two shifts. Second, since the trucks were a very early first generation product from BYD, there were occasions where the trucks would not generate as much power as a traditional diesel truck, making regular options more difficult than usual. Lastly, BYD had a very difficult time and was ultimately unable to integrate TTSI’s telematics systems provided by Omnitrac/Qualcomm.

When the demonstration first launched in December 2018, there was a discussion with TTSI regarding installing telematics on the truck. More specifically, TTSI uses a telematics hardware/software system provided by Qualcomm, and through testing with TTSI, learned that the Qualcomm vehicle monitoring unit (VMU) was not compatible with the BYD Phase 1 truck. BYD and TTSI thereafter considered an

alternative solution in the form of a Samsara VMU that BYD was already aware was compatible with the Phase 1 8TT trucks. The reason for not using Samsara was that TTSI needed to keep all of their trucks on the same VMU system for operational efficiency, and the fleet-wide expense would be too great to switch systems. BYD and Qualcomm (the current VMU provider for TTSI) worked together to find an appropriate hardware option to connect TTSI's in-cab computers to BYD's truck: a 16 to 9 pin OBDII adapter which BYD provided. However, parameters needed for TTSI's operations are outside of the SAE J1939 standard available on BYD trucks, so there was back-end data formatting required to supply Qualcomm's system with the necessary parameters for operation. BYD worked with Qualcomm to engineer and deploy the necessary solution in Q1 2019.

TTSI operated their trucks throughout April and May 2019. However, issues with the DMV interrupted their operation. The BYD trucks were titled to BYD Motors, with the registration expiring on May 31, 2019. BYD received the registration renewal notice at the end of April and mailed in the renewal with requisite payment on May 9, 2019. The DMV registration expired on May 31, 2019 without BYD having received the renewed registration. With the end of June approaching and no registration received, TTSI assisted BYD in reaching out to the DMV Headquarters in Sacramento to understand the delay. Through this conversation, BYD learned that the DMV was 90 days behind in processing mail-in registration renewals. It is unclear as to why the DMV sent out the notice for registration renewal 45 days prior to registration, with this known backlog. BYD was able to resolve this issue in Q3 2019.

As of Q4 2019, TTSI did not run the Phase 1 Trucks during the demonstration period due to (1) telematics issues resurfacing and (2) operator disinterest. BYD engineers further investigated the telematics issue but as noted below, this issue was never resolved. As for operator disinterest, despite offering additional driver training, the on-going feedback from TTSI was that the drivers did not like the cabs. TTSI ultimately sent the trucks back. These trucks were redeployed to 4Gen L10logistics in August 2021, where they continue to operate.

C. AJR Trucking

AJR's demonstration was severely hampered by one primary problem. A short time after the trucks were deployed, AJR moved to a different facility in Compton that did not have the requisite power supply needed for the trucks' chargers. More specifically, in December 2018, AJR relocated both of their trucks and chargers to a new facility and after AJR reinstalled their chargers at this new location, they kept receiving the same error code when attempting to charge. Though AJR installed the charger on a breaker that claimed to give 480V, BYD technicians found that the actual voltage provided was only 284V, causing the charging error. AJR engaged Southern California Edison (SCE) to determine the cause of the inadequate power. Although BYD made multiple site visits, including with SCE, BYD was not able to assist AJR in overcoming this problem. AJR had not resolved these charging issues as of December 31, 2021, so accumulated mileage for their two trucks was very low. AJR initiated an electrical infrastructure upgrade project at a total cost of over \$240,000 to deploy up to six DC fast chargers to support multiple battery electric trucks. This work is still ongoing and AJR is working with their contractor to complete EVSE installation by April 15, 2022.

Task 2.6 Phase 1 Truck Rework

As noted above, the Phase 1 trucks were underutilized for a variety of reasons. During the Phase 1 demonstration, some rework services were performed. The most notable rework occurred in Q1 2018

when BYD learned of a needed modification for the GSC truck, and also preemptively modified the TTSI and AJR trucks similarly. The modification was two-fold; first, the fifth wheel was pushed as far towards the rear of the truck as possible and, second, the bobtail was shaved down. This eliminated the possibility that the neck of a trailer chassis would scrape against the truck's bobtail. This was a large undertaking with the rework requiring approximately 80 cumulative labor hours per truck for the five Phase 1 trucks.

Task 2.7 Continued Demonstration of Phase 1 Trucks

As noted above, demonstration for four of the five Phase 1 trucks was significantly limited. The GSC truck was the most successful of the five, accumulating 16,261 miles as of December 31, 2021. The other four Phase 1 trucks accumulated between 800 – 2,200 miles as of December 31, 2021. The Phase 1 truck at GSC Logistics in Oakland will continue to have quarterly reporting on mileage as a requirement of the Bay Area AQMD funding which requires that trucks be deployed for five years.

Task 2.8 Begin Truck Production for Phase 2

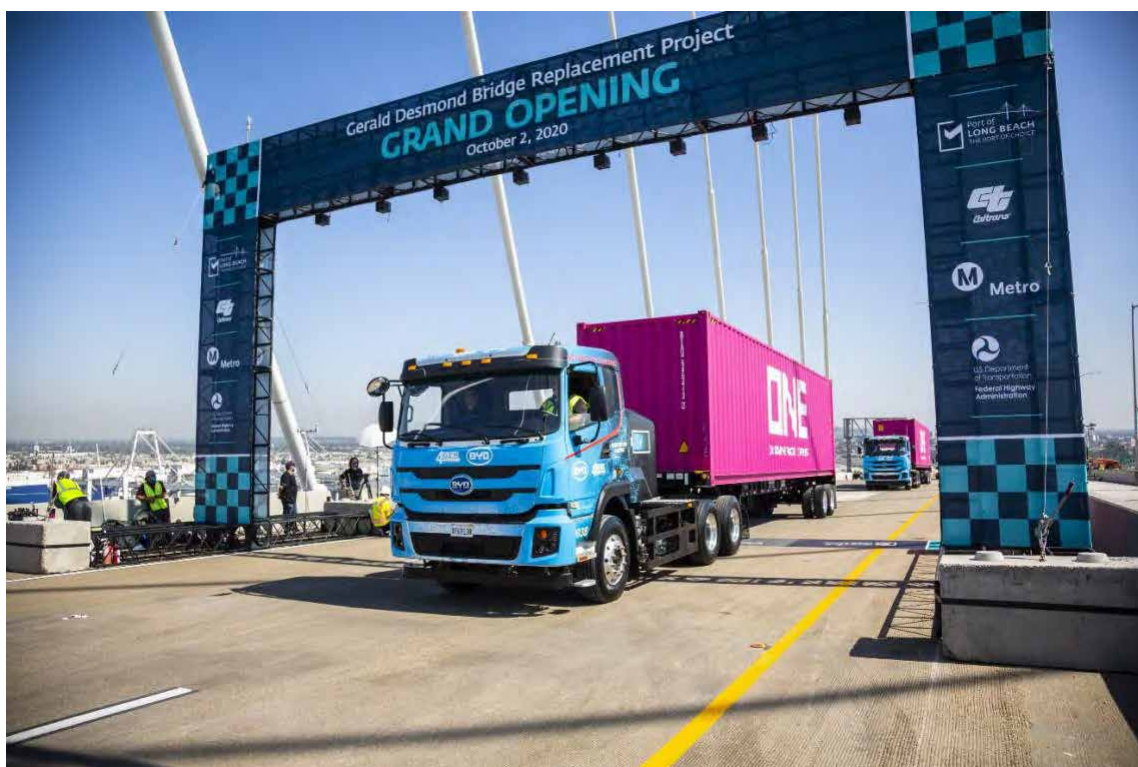

Figure 4 – 4Gen Logistics' BYD Phase 2 8TTs participating in the Gerald Desmond Bridge grand opening in 2020.

Based on the lessons learned from this and other deployments of the Gen 1 8TT, BYD commenced production of the Phase 2 trucks Gen 2 8TT in October 2018. By the end of March 2019, the first few chassis kits were shipped from Shenzhen, arriving at the Port of San Diego before being shipped up to Lancaster where they underwent final assembly before delivery to the fleets. Phase 2 trucks were demonstrated at 4Gen Logistics in Carson as shown above in Figure 4. The remainder of the chassis kits were received in Q2 2019.

A. Specifications

The Phase 2 trucks were designed and manufactured in BYD’s facilities in China. The trucks were produced to the following specifications as shown in Table 4 below.

Table 4 – BYD Phase 2 Battery Electric Truck Specifications

Chassis	BYD 8TT Phase 2
Length	278.3 in.
Width	100.4 in.
Height	121.3 in.
Wheelbase	166.3 in.
Curb Weight	26,235 lbs.
GCWR	105,000 lbs.
Top Speed	65 mph
Max Gradeability	25%
Range	125 miles
Wheel Rim	8.25x22.5
Tires	11R22.5
Suspension	Front: Leaf Spring, Rear: Air
Brakes	Front: Air Disc, Rear: Air Drum
Max Power	483 hp
Max Torque	1,770 ft. lbs.
Initial Battery Capacity	435 kWh
Charging Power	AC 40 kW + DC 120kW
Charging Time	11 hours AC / 3.5 hours DC

BYD made significant improvements to the Phase 2 8TTs compared to the Phase 1 trucks. The battery capacity was doubled and top speed, gradeability, horsepower, and torque were all increased. With respect to charging, BYD added DC CCS-1 charging connector capability to the trucks, which is now the standard in the U.S. MDHV market for high-powered fast charging, to allow compatibility with CCS1 DC fast chargers. However, the BYD chargers provided to the fleets utilize a BYD proprietary connector. This change allows not only for much higher power charging but also compatibility for customers to easily purchase these higher power fast chargers from any of the dozen DC fast charger manufacturers in the market, when fleets decide they would prefer to charge the Phase 2 8TTs at a higher rate. A more detailed overview and visualization of these changes is provided as **Attachment 1 – BYD Battery Electric Truck Phase 2 Design** in the BYD Appendix of the final report.

B. Certifications

The Phase 1 trucks were designed and manufactured in BYD’s facilities in China. The trucks were produced to the following certifications as shown in Table 5 below.

Table 5 – BYD Phase 2 Battery Electric Truck Safety Certifications

FMVSS	Test Name
101	Controls and Displays
102	Transmission Shift Position Sequence, Starter Interlock, and Transmission Braking Effect
103	Windshield Defrosting and Defogging Systems
104	Windshield Wiping and Washing System
106	Brake Hoses
108	Lamps, Reflective Devices, and Assoc. Equip.
111	Rear Visibility
113	Hood Latch System
119	New Pneumatic Tires for Motor Vehicles with a GVWR of more than 10,000 lbs.
120	Tire Selection and Rims and Trailer Load Carrying Capacity Information for Motor Vehicles with GVWR>10,000 lbs.
121	Air Brake Systems
124	Accelerator Control Systems
125	Warning Devices
205	Glazing Materials
207	Seating Systems
208	Occupant Crash Protection
209	Seat Belt Assemblies
210	Seat Belt Assembly Anchorages
302	Flammability of Interior Materials

The first two Phase 2 8TTs that were fully assembled, tested, and validated were delivered to Golden State Express in Compton and GSC Logistics in Oakland on June 19, 2019 and June 28, 2019, respectively. Subsequently, BYD fully assembled, tested, validated, and delivered six (6) trucks to fleets during the third quarter of 2019. Recipients included Golden State Express (1 truck in early July), GSC Logistics (1 truck in late August), TTSI (2 trucks in early/mid September), and Quik Pick Express (2 trucks in mid-September). Thereafter, the remaining twelve trucks were fully assembled, tested, validated, and delivered to fleets during the fourth quarter of 2019. Recipients included Sea-Logix (4 trucks in Oakland in October), 4 Gen Logistics (3 trucks in Wilmington in October), PASHA (1 truck in San Diego in November), and Anheuser Busch (4 trucks in Oakland in December). A detailed list of the Phase 2 truck deployments is presented in Table 6 below:

Table 6 – BYD Phase 2 Deployments

PHASE 2					
End User	Address	VIN	Deployment Area	EVSE	
				Qty	Charger Power
GSC Logistics	530 Water Street 5th Floor Oakland CA 94607	LA9TYDE86K1LC0047 LA9TYDE87K1LC0056	Port of Oakland	2	40 kW
4Gen Logistics	2400 E PCH Carson CA 90744	LA9TYDE80K1LC0044 LA9TYDE82K1LC0045 LA9TYDE88K1LC0051	Port of Long Beach	2	40 kW
TTSI	300 Ferry Street San Pedro CA 90731	LA9TYDE86K1LC0050 LA9TYDE85K1LC0041	Port of Long Beach	2	40 kW
Golden State Express	2999 E Pacific Commerce Drive Compton CA 90221	LA9TYDE89K1LC0057 LA9TYDE85K1LC0055	Port of Los Angeles	1	40 kW
Sea-Logix	1425 Maritime Street Oakland, CA 94607	LA9TYDE87K1LC0042 LA9TYDE89K1LC0043 LA9TYDE88K1LC0048 LA9TYDE80K1LC0058	Port of Oakland	4	40kW
Quik Pick Express	23610 Banning Blvd Carson, CA 90745	LA9TYDE80K1LC0061 LA9TYDE84K1LC0046	Port of Oakland	2	40kW
Pasha Distribution	1309 Bay Marina Drive San Diego, CA 91950	LA9TYDE81K1LC0053	Port of San Diego	1	40kW
Anheuser Busch	8380 Pardee Drive Oakland, CA 94621	LA9TYDE83L1LC0041 LA9TYDE85L1LC0042 LA9TYDE87L1LC0043 LA9TYDE89L1LC0044	Port of Oakland	3	40kW

Task 2.9 Fleet Registration Phase 2 and Integration into Fleets

All necessary documents for registration were provided to the fleets, including the weight slip, the Manufacturers Certificate of Origin, and the VIN verification. A half-day of operator training at each fleet primarily involved a familiarization with the start sequence and testing different chassis connections for compatibility, in addition to charging protocol. All fleets ultimately added the trucks to their Port Drayage Truck Registry where applicable.

There were a range of outcomes when working to find fleets to operate the trucks in this program. Both TTSI and GSC were already participating in the program with the Phase 1 trucks, so there was a relatively straight-forward ask for these fleets to incorporate Phase 2 trucks into their fleets as well. For the other fleets, there were still concerns about tax liabilities and range issues, but BYD was able to work with several fleets to overcome these concerns. These fleets included: Golden State Logistics, Quik Pick Express, 4 Gen Logistics, Sea-Logix, and Pasha Distribution Services. These fleets were all able to incorporate these Phase 2 trucks into their fleets in 2019 into early 2020. Considering this is a relatively broad representation of the types of drayage fleets that are able to take on these new technology demonstration projects, BYD had trouble finding a fleet to take the final four Phase 2 trucks. Accordingly, BYD suggested to South Coast AQMD and CARB that Anheuser Busch in Oakland would be a great partner to take the remaining four trucks. Based on BYD's pre-existing relationship with Anheuser Busch, they were capable of putting these trucks into regular service and eager to do so. These trucks were put into regular service starting in December 2020 and continue to operate.

An important point to note is that some fleets had difficulty bringing the trucks onto their insurance plans, with the stated reasoning from the insurance companies that the battery pack is a combustion risk. Given the combusting nature of the internal combustion engine, this insurance industry perception was discouraging. Moreover, as noted above, the chance of a BYD FE battery causing a fire is extremely low. Fleets requested BYD share literature on the safety of BYD batteries.

Task 2.10 Phase 2 Demonstration

There were varying degrees of success in deploying the Phase 2 trucks, with challenges often coming from unexpected places. All of the trucks were deployed using BYD's 40kW AC charger to charge the trucks. As detailed above, these chargers provide a low-cost, easy to install charging option for fleets. The specific deployments of each fleet is discussed below. The Phase 2 trucks at GSC Logistics, Sea-Logix, and Anheuser Busch in Oakland will continue to have quarterly reporting on mileage as a requirement of the Bay Area AQMD funding which requires that trucks be deployed for five years.

A. Golden State Logistics and Quik Pick Express

Golden State Logistics in Compton (GSE) and Quik Pick Express in Carson (QuikPick) were two of the most straight-forward Phase 2 deployments, and, therefore, accumulated the most mileage over the course of the demonstration period. As of December 31, 2021, GSE's two trucks that it received at the beginning of the project accumulated 32,119 and 24,912 miles. QuikPick's trucks accumulated even more miles during the same period, totaling 34,899 and 25,808 miles. Clearly GSE and QuikPick regularly used these four trucks, with very little down time. GSE was particularly enthusiastic about the trucks, going so far as to install an electric truck-specific wrap on the trucks and providing the truck for display at the Harbor Trucking Associate DrayTech event in Long Beach in March 2020, shown below in Figure 5.



Figure 5 - GSE Phase 2 8TT with Electric Truck Wrap at DrayTech event in Long Beach in March 2020

B. 4Gen Logistics

4Gen Logistics (4Gen) is a logistics company based in Rialto but operated its three trucks out of a yard in Wilmington. 4Gen was also able to accumulate significant mileage but the initial implementation of the Phase 2 trucks was slightly delayed due to registration and infrastructure issues. When 4Gen first received the trucks, it encountered some problems registering the trucks with the Ports of Los Angeles and Long Beach drayage truck registry called eModal. After a month, 4Gen was able to resolve the issue relatively quickly after interfacing directly with the San Pedro Bay Ports. In addition, as mentioned above, the BYD AC chargers operate on a four-wire interface. The facility that 4Gen operated the three trucks in Wilmington was utilizing a three-wire configuration. Although this problem created some delay in deployment, 4Gen was able to overcome this issue by working with its electrician to install a new transformer that provided four-wire power. After that, all three trucks were operating on a regular basis. As of December 31, 2021, the three 4Gen trucks accumulated 48,107 miles in total.

C. Sea-Logix

Sea-Logix in Oakland (SLX) was another fleet that had generally few problems during its deployment. There were no major concerns or issues, just normal maintenance and wear-and-tear maintenance needs. There were some issues with spare parts availability. One of the trucks was involved in a crash of its front end bumper that was not serious in nature but put the truck out of service from March to May 2020 due

to spare parts not being available. However, overall BYD was able to remedy the issue and provide other service as needed. As of December 31, 2021, the four SLX trucks accumulated 43,767 miles in total.

D. Total Transportation Solutions

TTSI's operations of the Phase 2 trucks was, like the Phase 1 trucks, short-lived, for some of the same reasons: telematics and driver acceptance. With respect to telematics, there was an extended period of time in 2020 where none of the TTSI trucks were operating. This was due to (1) the telematics problem resurfacing, (2) turnover in BYD's project management team, and (3) no access to data from the data loggers. Eventually this was rediscovered as a problem in the fall of 2020 during an exchange between BYD and TTSI. In November 2020, BYD visited the TTSI facility with the Qualcomm team to try to fix the issue. Some issues were resolved while the parameters issue noted above persisted. BYD's engineering team thereafter engaged in regular communications with Omnitracs and Qualcomm but the issue was never resolved. Soon after, TTSI decided to send the trucks back to BYD due to lack of use. After BYD took the trucks back, they were cleaned up and reworked, and then sent to GSE for redeployment since they had so much success in deploying their first two Phase 2 trucks. GSE received these trucks in August 2021, where they continue to operate.

E. Pasha Distribution Services

Pasha Distribution Services in San Diego (Pasha) encountered various problems throughout the demonstration period. The first problem arose in late 2019 when Pasha notified BYD that it was no longer in possession of a trailer that could move the vehicles the truck was intended to move. Subsequently, Pasha was unable to find a replacement trailer for quite some time. Pasha completed a deal for a replacement trailer in May 2020 but COVID slowdowns impacted the need for acquiring the trailer. Subsequently, Pasha identified two new issues impacting use of the trucks: (a) COVID-19 pandemic led to a shortfall in volumes due to overseas auto manufacturing plants still recovering from their shutdowns in Q2 2020 and (b) the charging station had not yet been installed by San Diego Gas & Electric as of July 2020. Taking the latter item first, the charger installation was completed by the end of August 2020.

Impacts from the COVID-19 pandemic persisted through 2021. Unlike the increased volumes generated at the Ports of Los Angeles and Long Beach during the pandemic, demand for the car transport and related service provided by Pasha at the Port of San Diego dramatically decreased, meaning Pasha had no need for operating its electric truck. As of December 31, 2021, Pasha had not resumed use of this truck. However, in March 2021, PASHA advised BYD that it had been awarded an auto haul-away business with an estimated start date of early 2022, committed to running that service with its electric truck, and agreed to collect this data for the duration of 2022 as a supplement for time missed during COVID. BYD subsequently presented this offer to South Coast AQMD and CARB which was accepted by both agencies.

F. Anheuser Busch

Lastly, as noted above, Anheuser Busch in Oakland (AB) participated in the program, operating four trucks in total and encountering some persistent problems along the way. The first problem was with the electrical infrastructure design for the facility where the trucks would be domiciled. The infrastructure design was impacted by logistical and health issues internal to AB that delayed infrastructure deployment until March 2020. Subsequent to completion of infrastructure installation, AB began focusing on DMV vehicle registration but that effort had not been resolved by the end of Q1 2020. Unfortunately DMV registration issues persisted throughout Q2 and Q3 2020 and were only finally resolved in in early October

2020, followed by operator training and operations launch on October 15, 2020. Not long after launching operations, AB encountered another issue with the lift gate on the trucks. AB trucks run a duty cycle that is highly urban with 10+ stops per day, each requiring significant lift gate usage. This utilization is multiple times more intense than any other customer using the BYD 8TT. Because of this, after several months of trial and error, BYD concluded that our original configuration was not able to provide sufficient voltage to recharge the trailer batteries because BYD's low-voltage system is a 24V system, which is different from most heavy duty vehicles that have 12V systems. Subsequently, BYD's engineering and service teams reviewed the design and found a way to better optimize the equalizer, enabling higher voltage to the trailer. This solution was tested by both BYD and Vehicare (AB's service provider) and accepted as a complete solution to the issue in July 2021. Despite these challenges, AB is very satisfied with the electric trucks, having accumulated 29,159 miles across its four trucks as of December 31, 2021.

Based on the feedback regarding the fleets' experiences with the electric trucks, BYD believes that this project will catalyze additional battery electric truck uptake not only by the participating fleets, but also related fleets. With respect to the participating fleets, 4Gen and AB have indicated that they will add more Class 8 battery electric trucks to their fleets, and just need to work out how they can receive grant funding to help cover the difference from a diesel truck in up-front costs. GSE, QuikPick, and SLX all noted that their experience will be an important factor and decisions point in figuring out how best to add more battery electric trucks to their fleets.

With respect to fleets outside this grant program, the first expected catalyst to battery electric truck uptake is the GGRF ZEDT project itself. This deployment has shown clearly that fleets operating all over California calling at different Ports and moving different types of goods were able to successfully accumulate 300,000 miles of real world battery electric truck experience. Moreover, when these fleets add more battery electric trucks in the near- and medium-term, it builds on what this project has shown, namely that these fleets believe in the utility and capabilities of battery electric trucks.

Task 2.11 Project Reporting

A significant amount of data was collected throughout this project, both qualitative and quantitative. From the qualitative side, BYD was tasked with providing quarterly progress reports that detailed the progress of the project during the preceding quarter, including progress updates and details of problems encountered. In addition, BYD provided detailed maintenance reports that catalogued the maintenance issues encountered and solutions provided as well as other details. In addition, BYD collected significant quantitative data, in the form of monthly odometer readings for each month for all trucks. Please see the discussion under Task 2.2. EVSE Installation and Data Collection above for a more detailed discussion of data collection and reporting.

Task 2.12 Market Assessment Draft and Final Market Assessment

The Market Assessment Report for this project was drafted by CALSTART, a nonprofit organization working to build a high-tech clean-transportation industry that creates jobs, cuts air pollution and oil imports and curbs climate change. The first draft of the Market Assessment Report was submitted to South Coast AQMD on September 1, 2020. After an extensive review by both South Coast AQMD and CARB, the Market Assessment Report was sent back to CALSTART for additional drafting, which was subsequently completed and submitted to South Coast AQMD on January 12, 2022. There was very

significant progress and updates in the final Market Assessment Report, growing from a 34-page document in the first draft to an 87-page document in its current form. In addition, the report is an extensive deep-dive into the current state of the Class 8 drayage truck market and a thorough analysis of the opportunities and barriers to large-scale conversion of the California drayage truck market to zero-emission trucks.

The GGRF ZEDT project had a large impact on the development of the third generation 8TT (Gen 3 8TT) released at the Advanced Clean Transportation Expo in Long Beach in September 2021. The BYD Gen 3 8TT was used to haul Bud Light beer to the 2022 Super Bowl in Los Angeles as shown in Figure 6 below.



Figure 6 - BYD Gen 3 8TT Hauling Bud Light to Super Bowl in Los Angeles in 2022

The Gen 3 8TT includes a host of new features including an exterior redesign, significant upgrades to the cab to increase driver comfort, safety features like Advanced Driver Assist Systems (ADAS) and Adaptive Cruise Control, and keyless entry. BYD already has orders for over 250 of these trucks, including a recently-announced 200 truck order in February 2022 from Einride.¹ Specifications for the Gen 3 8TT are included in **Attachment 2 – BYD Gen 3 8TT Truck Design** of the BYD Appendix of the final report.

¹ <https://en.byd.com/news/byd-and-einride-sign-largest-ever-order-for-heavy-duty-battery-electric-trucks-outside-of-asia/>.

Montes De Oca, Cuauhtemoc A.
Clean Transportation Program

Clean Transportation Program

GGRF FINAL PROJECT REPORT

Prepared for: California Air Resources Board

Prepared by: Transportation Power, LLC

Gavin Newsom, Governor

March 2022 | CARB-G14-LCTI-09

Montes De Oca, Cuauhtemoc A.

Authors:

Frank Falcone

Cuauhtemoc A. Montes de Oca

Transportation Power, LLC

2415 Auto Park Way

Escondido, CA 92029

Agreement Number: G14-LCTI-09

Earl Landberg

Staff Air Pollution Specialist

DISCLAIMER

This report was prepared as the result of work sponsored by the Southern California Air Quality Management District (SCAQMD). It does not necessarily represent the views of the SCAQMD, its employees, or the State of California. The SCAQMD, the State of California, its employees, contractors, and subcontractors make no warrant, express or implied, and assume no legal liability for the information in this report; nor does any party represent that the use of this information will not infringe upon privately owned rights. This report has not been approved or disapproved by the SCAQMD nor has the SCAQMD passed upon the accuracy or adequacy of the information in this report.

ACKNOWLEDGEMENTS

- Biagi Brothers Trucking
- Werner Enterprises
- Estes
- Los Angeles Department of Water and Power
- PepsiCo
- Harris Ranch Beef
- BAE Systems
- NFI Inc.
- Oak Harbor Freight Lines

- Daylight Trucking
- Southern California Edison
- Benore Logistics
- Total Transportation Services
- Peterbilt
- Transpower, LLC
- Meritor Electric Vehicles

PREFACE

CARB Greenhouse Gas Reduction Fund (GGRF) Zero Emission Drayage Truck Demonstration Project (ZEDT) is funded through a FY 2014-15 grant for the Air Quality Improvement Program and Low Carbon Transportation Greenhouse Gas Reduction Fund Investments. The GGRF ZEDT project is part of California Climate Investments (CCI), a statewide initiative that puts billions of Cap-and-Trade dollars to work reducing greenhouse gas emissions, strengthening the economy, and improving public health and the environment – particularly in disadvantaged communities. The GGRF ZEDT project is funded through CARB grant G14-LCTI-09 to deploy 44 pre-commercial zero and near-zero emission Class 8 battery electric, CNG and diesel hybrid electric drayage trucks along with supporting infrastructure that will be operated in revenue service throughout the state at the Ports of Los Angeles, Long Beach, San Diego and Oakland in the South Coast AQMD, Bay Area AQMD, San Joaquin Valley APCD, and San Diego APCD jurisdictions.

CARB's Greenhouse Gas Reduction Fund provides financial support for projects that:

- Reduce California's use and dependence on petroleum transportation fuels and increase the use of alternative and renewable fuels and advanced vehicle technologies.
- Produce sustainable alternative and renewable low-carbon fuels in California.
- Expand alternative fueling infrastructure and fueling stations.
- Improve the efficiency, performance, and market viability of alternative light-, medium-, and heavy-duty vehicle technologies.
- Retrofit medium- and heavy-duty on-road and nonroad vehicle fleets to alternative technologies or fuel use.
- Expand the alternative fueling infrastructure available to existing fleets, public transit, and transportation corridors.
- Establish workforce-training programs and conduct public outreach on the benefits of alternative transportation fuels and vehicle technologies.
- Improve public health and environment particularly in disadvantaged communities

To be eligible for funding under the Greenhouse Gas Reduction Funds zero-emissions drayage truck program a project must be consistent with CARB's goals. CARB issued GGRF ZEDT project funds through CARB grant G14-LCTI-09 to cost share the development of truck demonstrations.

ABSTRACT

The twelve (12) truck Greenhouse Gas Reduction Funds (GGRF) GGRF project was funded by the California Air Resource Board's 2014-2015 grant for Air Quality Improvement Program and Low Carbon Transportation Greenhouse Gas Reduction Fund Investments. Project trucks demonstrate the feasibility of utilizing battery-electric systems in Class 8 Drayage range trucks. Drayage trucks are conventionally fueled by diesel fuel and typically travel short distances daily (100-200 miles). Drayage trucks typically operate multiple cold start cycles and high idle times. Communities surrounding manufacturing facilities suffer multiple stop deliveries and disproportionate exposure to tailpipe emissions. Exposure is known to negatively affect residents, workers, and operator's health. Battery-electric systems offer a zero-emissions solution to the drayage truck segment replacing the high emissions from cold-start driving and running idle time with tailpipe emissions.

The GGRF ZEDT project successfully designed and built twelve battery-electric drayage trucks using the TransPower/Meritor electric powertrain and Peterbilt 579 chassis. These trucks were newly built electric drayage trucks building on previous versions of TransPower's "ElecTruck" technology. GGRF ZEDT utilized more advanced batteries, powertrain technology, and lessons learned in contrast to prior drayage truck projects. Fleet operators of acknowledgement section demonstrated the electric drayage truck units in real-world typical drayage duty cycles.

The diversity of fleet participants provided real-world data to use in scoping best use pattern cases for large scale deployment battery electric drayage trucks. Many important lessons were learned by the electric truck manufacturer and fleet operators in deployment of electric drayage trucks on how to prepare for, receive, operate, and service electric heavy-duty drayage trucks. Lessons learned during this project promoted significant changes of powertrain configuration and battery cell chemistry of commercialized drayage trucks.

By April 2022 GGRF ZEDT accumulated more than 125,300 miles. Tremendous learning occurred related to truck reliability, best use patterns, and cost of ownership during mileage accumulation. Through development funded by GGRF ZEDT monies, Peterbilt Motors, Kenworth Trucks and Meritor Electric Vehicles dba TransPower, LLC have moved into commercial production of battery electric drayage trucks.

Keywords: Peterbilt, TransPower, Meritor, electric drayage truck, battery-electric, zero-emissions, heavy-duty, clean vehicle, clean transportation, electrification, 579ev

Please use the following citation for this report:

Montes de Oca, Cuauhtemoc A., Falcone, Frank. 2022. *California Collaborative Advanced Technology Greenhouse Gas Reduction Fund Zero-Emission Drayage Truck Demonstration*. California Air Resources Board. Publication Number: CARB-G14-LCTI-09

TABLE OF CONTENTS

Page	
Acknowledgements.....	iii
Preface	4
Abstract.....	5
Table of Contents.....	7
List of Figures	8
Executive Summary.....	10
CHAPTER 1: Introduction.....	11
TransPower Background	11
The Drayage Truck Industry	11
Grant Project Overview.....	13
CHAPTER 2: Electric Truck Build	15
Rolling Chassis	15
Computer Aided Design Studies	15
Design.....	17
Integration.....	29
Lessons Learned	27
CHAPTER 3: On-Road Demonstration	42
Overview.....	42
Key Challenges	42
CHAPTER 4: Lessons and Improvements	45
Key lessons and future improvements.....	45
Commercialization and Design Improvements	45
CHAPTER 5: Conclusion.....	47

LIST OF FIGURES

Page

<i>Figure 1:</i> Peterbilt 579 GGRF Rolling Chassis	14
Figure 2: Peterbilt 579 GGRF Trucks at Advanced Clean Transportation Show	14
<i>Figure 3:</i> Prior Version of TransPower’s ElecTruck.....	16
<i>Figure 4:</i> Redesigned Battery Electric Energy Storage System	17
<i>Figure 5:</i> Nickel, Manganese, Cobalt (NMC) Battery Modules.....	18
<i>Figure 6:</i> PCAS Assembly Line	19
<i>Figure 7:</i> CAD representation of PCAS Assembly	20
<i>Figure 8:</i> Peterbilt 579EV Component Integration Stall	21
<i>Figure 9:</i> Rolling Chassis of Trucks 2 thru 4 (First, Second, and Fourth Truck from Left)	22
<i>Figure 10:</i> Heavy-Duty MDS Sub-system Installed in GGRF Project Truck	23
<i>Figure 11:</i> GGRF Trucks 5 thru 8 in Integration Stalls.....	24
Figure 14: Assembled Battery Modules Prior to Installation into Frame Rail Cases.....	27
Figure 15: TransPower NMC power Peterbilt 579 truck Climbing Pikes Peak CO and at Tradeshow	28
Figure 16: Peterbilt 579 with TransPower’s Electric Drive System 8 strings of the NMC ESS system	28
Figure 17: MDS, inverters, motors and gearbox installed	30
Figure 18: PCAS structures and Heavy-Duty MDS assemblies prior to integration into chassis	31
Figure 19: Completed GGRF 579EV	32
Figure 20: GGRF ZEDT Peterbilt 579 Class 8 Tractor Rolling Chassis at Factory	33
Figure 21: Meltric brand shore power plug and receptacle	33
Figure 22: Complete EVSE with transformer and charge control box	34
Figure 23: Image of Operator Connecting Charge Cable to GGRF ZEDT Truck.....	36
Figure 24: Image of Transpower Electrically Driven Drayage Truck Charging at Public Charger in Sunnyvale, California	36
Figure 25: GGRF ZEDT During CCD Testing.....	38
Figure 26: GGRF ZEDT During CCD Testing.....	39

Figure 27: GGRF ZEDT Peterbilt 579ev with Transpower Electric Drive System 40
Figure 28 HVIP Voucher for Peterbilt 579EV Available 47

EXECUTIVE SUMMARY

Based in San Diego County TransPower, LLC created a proprietary ElecTruck™ designed as a modular electric system for use in powering drayage, refuse, and terminal tractor applications. First of a kind TransPower and Peterbilt battery electric trucks led to full commercial production 579EV available to the public for purchase.

The U.S. Drayage sector of logistics supply chains perform more than 60 million drayage movements each year across North America. Drayage service is a specialty logistics service that carries freight over short distances. Drayage is critical to intermodal shipping. Drayage shipping refers to movement of containers arriving by sea, rail, or other trucks.

By the nature of drayage trucking the movements occur within the same metropolitan area in which the truck picks up its freight. (Citation for preceding paraphrasing-[What is Drayage Service and How it Works | ABCO Transportation \(shipabco.com\)](#)) The Drayage industry operates Class 8 units with generally near 100% percent using diesel fuel ([Drayage Truck Best Practices to Improve Air Quality | US EPA](#)). A battery-electric drayage truck emits zero tailpipe emissions and help manufacturers meet upcoming state regulatory sales requirements. To demonstrate the GGRF ZEDT trucks in real-world conditions, TransPower brought in as project partners 14 organizations:

- Werner Enterprises
- Estes
- PepsiCo
- BAE Systems
- TTSI
- Biagi Brothers
- Los Angeles Department of Water and Power
- NFI Logistics
- Southern California Edison
- Daylight
- Oak Harbor
- Harris Ranch Beef
- Benore Logistics
- AJR

These partners deployed the GGRF ZEDT trucks throughout California and in a single circumstance South Carolina. The GGRF ZEDT trucks accumulated real-world mileage throughout South Coast AQMD, Bay Area AQMD, San Joaquin Valley APCD, and San Diego APCD jurisdictions proving battery electric drayage truck performance in a wide variety of real-world land transportation operations.

Many lessons were learned over the course of the project including things such as extent of electromagnetic interference impact on performance, real versus designed range, temperature impacts on battery, long-term inverter reliability, roll stability interface, harness build quality, Energy Storage System (ESS) module sealing, operator and route impact on overall range, EVSE installation timelines, and robustness of controller software.

CHAPTER 1:

Introduction

TransPower Background

Transportation Power, Inc. (TransPower) was founded in 2010 for the express purpose of manufacturing components for zero-emission medium and heavy duty vehicles Class 6,7, and 8. In January 2020, TransPower was fully acquired by Meritor, Inc. becoming TransPower LLC and operates as a subsidiary in support of the brand Meritor Electric Vehicles. The company remains based in Escondido, CA, located in San Diego County. Recently announced at the time of this report, Cummins Inc. entered a definitive agreement to acquire Meritor Inc. parent company to TransPower.

TransPower deployed some of the first heavy-duty battery-electric vehicle applications in California hauling its first revenue load out of the Port of LA in 2013. TransPower has converted from diesel to battery power some of the largest road vehicles and yard tractors, with gross combined weights up to 150,000 pounds.

TransPower's California-based demonstration vehicles, powered with the proprietary ElecTruck™ drive systems and components, remains a competitive solution that is still being applied to medium- and heavy-duty applications today.

The Drayage Truck Industry

Drayage trucks have duty cycle requirements that are typically within 100 to 200 miles of daily range. Cycles include typical to and from cargo container terminals, short range delivery or pickup/delivery across residential areas.

It is well known that diesel-powered trucks pollute least in non-transient steady state operation with engine at normal operating temperature. Drayage trucks fall short of being as ecologically friendly as their over-the-road counterparts in regular short-haul use. The duty cycle of drayage trucks provides for multiple high polluting operation segments associated with cold start and warm up periods of diesel-powered trucks. Diesel powered drayage trucks disproportionately contribute to negative impacts seen in areas through which they operate.

Electric drayage trucks are 100% cleaner than diesel powered trucks in the same cycles producing zero-tailpipe emissions. Electric drayage trucks remove carbon dioxide (CO₂) and criteria pollutants produced at the tailpipe from diesel engine trucks. Criteria pollutants removed include of all sizes of particulate matter (PM 10, 2.5, and ultrafine) NO_x, and others.

As the electric grid moves towards renewable energy sources, the potential of electricity as an energy carrier ushers in the cleanest transportation era in industrial history. Decarbonization of the electrical grid along with deploying electric heavy-duty trucks directly supports the National Academy of Engineering Grand Challenge (NAEGC) of developing Carbon Sequestration Methods.

The U.S. Drayage truck market has a forecasted worth about \$29 billion per year from 2020 – 2025 with incremental increases of 7.66% ([Drayage Market Procurement Intelligence Report with COVID-19 Impact Analysis | Global Forecasts, 2020-2024 | Business Wire](#)). There are about 23 manufacturers of trucks in North America. Original equipment manufacturer (OEM) Peterbilt, a GGRF ZEDT collaborator, represents one of the largest manufacturers of Class 8 trucks.

The potential for scaled adoption of electric drayage is observed in the overall results of this project. Using recent policy passed in California as reference electric drayage may displace diesel fueled drayage short-term.

Under the recently passed California Advanced Clean Truck Regulation the California Air Resources Board (CARB) mandates manufacturers increase percentages of zero-emission Class 8 trucks from 9% - 50% - 75% over 2024 – 2030 – 2035 respectively.²

This mandate specifies that heavy duty truck manufacturers meet zero-emission requirements by selling either battery-electric or hydrogen fuel cell trucks ahead of the required deadlines.

A complete overhaul of diesel drayage to zero-emissions sales requires intensive reliability testing of electric powertrains, significant advancement in battery technology, sophistication of Electric Vehicle Service Equipment (EVSE) permitting processes, more robust electrical grid, and increased incentives.

² California Air Resources Board. 2020. *Advanced Clean Trucks*. (<https://ww2.arb.ca.gov/our-work/programs/advanced-clean-trucks>)

Grant Project Overview

During the initial award of GGRF ZEDT in 2016, battery-electric drayage trucks were nascent technologies. By the deployment of the 12 GGRF ZEDT demonstration trucks nearly all major OEMs had made commitments to produce zero-emission trucks with most announcements focused on battery-electric technology. TransPower received strategic investments from Meritor Inc. as part of the traditional heavy-duty manufacturers interest in electric trucks. In 2020 Meritor Inc. acquired Transpower and took control over TransPower's participation in the GGRF project.

Like other short-range heavy-duty vehicle applications, electrification of drayage trucks represents a segment ideally fit for battery-electric power. Multiple short hauls, a home base for charging infrastructure, lots of stop/start delivery, and regenerative braking opportunities make up the duty cycle. Drayage like the refuse sector is a beachhead for adoption of zero-emissions powertrain technology with relatively low range needs. TransPower's experience with drayage trucks, school buses, and yard tractors was applied to the GGRF ZEDT project.

TransPower's experience building electric heavy-duty tractors allowed lessons learned throughout the project to find their way into mid-project and field changes as improvements. Improvements subsequently proved battery electric drayage as a viable replacement for diesel powered trucks.

The GGRF ZEDT project built 12 Peterbilt brand Model 579 electric drayage in two phases. Phase 1 of the project-built truck 1-4 and Phase 2 built trucks 5-12. Project trucks carried a range of battery storage from 264kWh to 352kWh to demonstrate duty cycle-based battery module scalability. GGRF trucks demonstrated for a period of five years for 10 trucks and six years for two trucks. All twelve trucks were built and commissioned at TransPower before deployment with fleets.

Figure 1: Peterbilt 579 GGRF Rolling Chassis



Photo of Two hauling trucks delivering 6 Peterbilt 579 Rolling Chassis in Towing Configuration Credit: TransPower

Figure 2: Peterbilt 579 GGRF Trucks at Advanced Clean Transportation Show



Six of twelve GGRF ZEDT Funded Battery Electric Drayage Trucks Credit: <https://highways.today/2019/04/25/peterbilt-electric-trucks-act/>

CHAPTER 2:

Electric Truck Build

Rolling Chassis

The all trucks built with GGRF ZEDT dollars used the Peterbilt (PB) Model 579 complete rolling chassis. Rolling chassis signifies a complete road ready Class 8 truck minus its powertrain (i.e. diesel engine and transmission).

Computer Aided Design Studies

TransPower used computer aided design (CAD) to model the Peterbilt 579 fitted with TransPower's Heavy-Duty Motive Drive System (MDS), potential battery storage systems, and all other necessary components needed to create a fully functioning heavy duty electric truck. After comparing alternatives offered by Peterbilt and supplier Rush Industries, it was decided to order the 579 series truck rolling chassis from Peterbilt, instead of taking delivery of completely built diesel fueled trucks and then removing the drive components as done by Transpower in past projects. Peterbilt Model 579 rolling chassis are complete operable trucks minus the powertrain, and controllers.

This approach is much better suited for serial production than receive complete vehicles requiring extensive disassembly. However, since Peterbilt did not have a rolling chassis definition optimized for electrification it was decided to collaborate with Peterbilt to create EV rolling chassis. Through the process, TransPower and Peterbilt exchanged computer models refining the chassis specification to best suit electrification.

The 12 GGRF ZEDT rolling chassis are typical of a class 8 tractor with extended front hood. Prior Class 8 tractors built by Transpower were not of Peterbilt Motors make. Building project Peterbilt trucks required unique electrical cable design to fit the trucks well. The design of both high power and signal cables followed the structural arrangement designs with production for the low volume of 12 trucks occurring using a scale model for actual length reproduction after CAD taking into account power cables fabrication to order in China, and a typical lead time of 3-4 months.

Design

Design of this iteration of TransPower's "ElecTruck" took the lessons learned on prior projects (See Figure 3). TransPower's decades long heavy-duty electrification placed it at the forefront of electric truck design. Original project energy storage designs were changed mid-project to most effectively use the GGRF ZEDT monies allocated for the 12-truck build. GGRF ZEDT project trucks underwent design improvements including relocations of components to secure and accessible locations and lighter more power dense batteries. Redesigns were spurred by evolving proprietary Transpower auxiliary inverter and battery management software.

Figure 3: Prior Version of TransPower's ElecTruck



Photo of TransPower's Previous Battery Electric Truck Built as Part of EDD Grant Project Credit:
TransPower

Integration

Build schedule was outlined in the award agreement. The following is a breakdown of actual task completion versus scheduled completion dates.

Development and completion of Phase 1 concept design occurred two months early. Early completion reflected TransPower's readiness for designing new generations of electric drayage trucks.

Phase 1 ESS subsystem assembly completed 9 months behind schedule (See Figure 4). Delays in ESS assembly are attributable to the decision to change battery cell technology to the more power dense and lighter Nissan Leaf Nickel Manganese Cobalt (NMC) batteries (See Figure 5). Moving to the better batteries required a complete redesign of the ESS assembly planned for the GGRF ZEDT 579ev. The pros and cons of this change's impact on project timeline were weighed. The delay in project completion from the battery cell change was justified by the significant improvement in operating range NMC batteries brought to the project.

Figure 4: Redesigned Battery Electric Energy Storage System



**Picture of Transpower Technicians Assembling Redesigned Modular ESS
Credit: Transpower**

Figure 5: Nickel, Manganese, Cobalt (NMC) Battery Modules



Photo of NMC Battery Assemblies Before Installation into Modular Enclosures Credit: Transpower

Phase 1 Powertrain Control Accessories System (PCAS) subsystem completed six and a half months late (See Figure 6 and 7). PCAS was delayed due to behavior exhibited during testing and ESS redesign. The PCAS showed torsional instability during minor truck movements. Transpower resolved this movement with the addition of a reinforcing bracket. Resolving torsional movement was an engineering challenge. The majority of project delay is attributable to ESS redesign. A new PCAS bracket followed ESS redesign as a lower priority.

Figure 6: PCAS Assembly Line



Photo of PCAS Assemblies in Build Process Credit: TransPower

Figure 7: CAD representation of PCAS Assembly

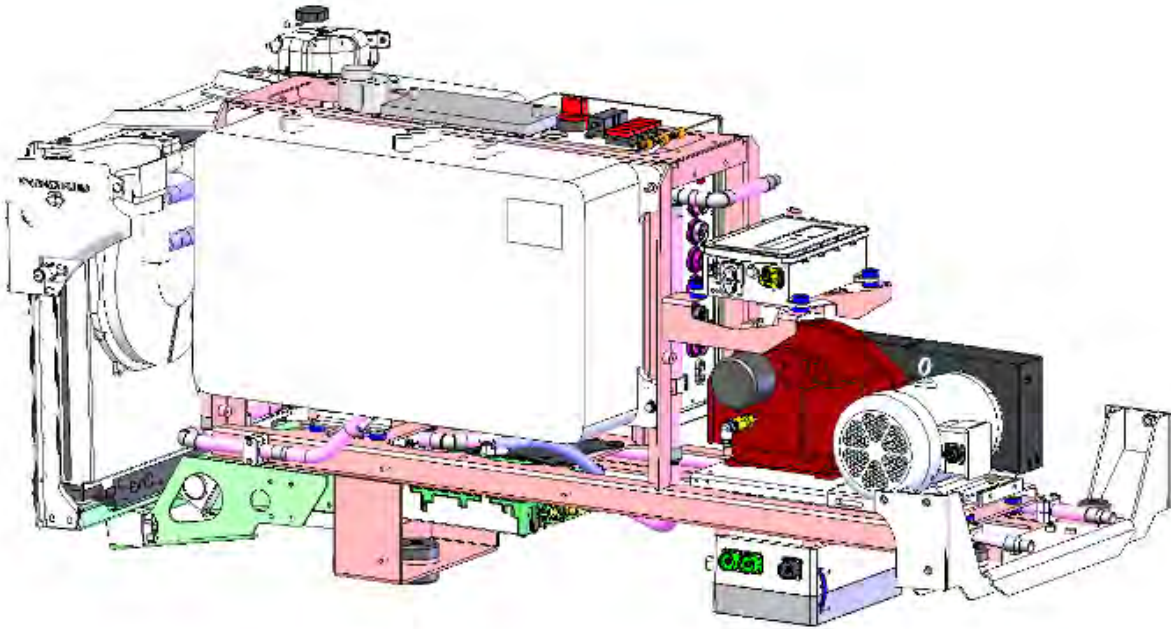

Class 8 PCAS for Peterbilt Model 579EV. Credit: TransPower LLC

Integration of the first GGRF ZEDT Model 579ev occurred 3 months late. Delay of integration is attributable as a ripple effect of the ESS redesign discussed above.

Figure 8: Peterbilt 579EV Component Integration Stall



Photo of 579ev During Integration Process Credit: TransPower

Integration of trucks two through 4 completed 6 months behind schedule and is also attributable to the ESS redesign (See Figure 9 and 10). ESS redesign was completed during this period and proper quantity of batteries were ordered to build remaining 8 trucks allowing Peterbilt and Transpower to regain ground on the planned schedule.

Figure 9: Rolling Chassis of Trucks 2 thru 4 (First, Second, and Fourth Truck from Left)

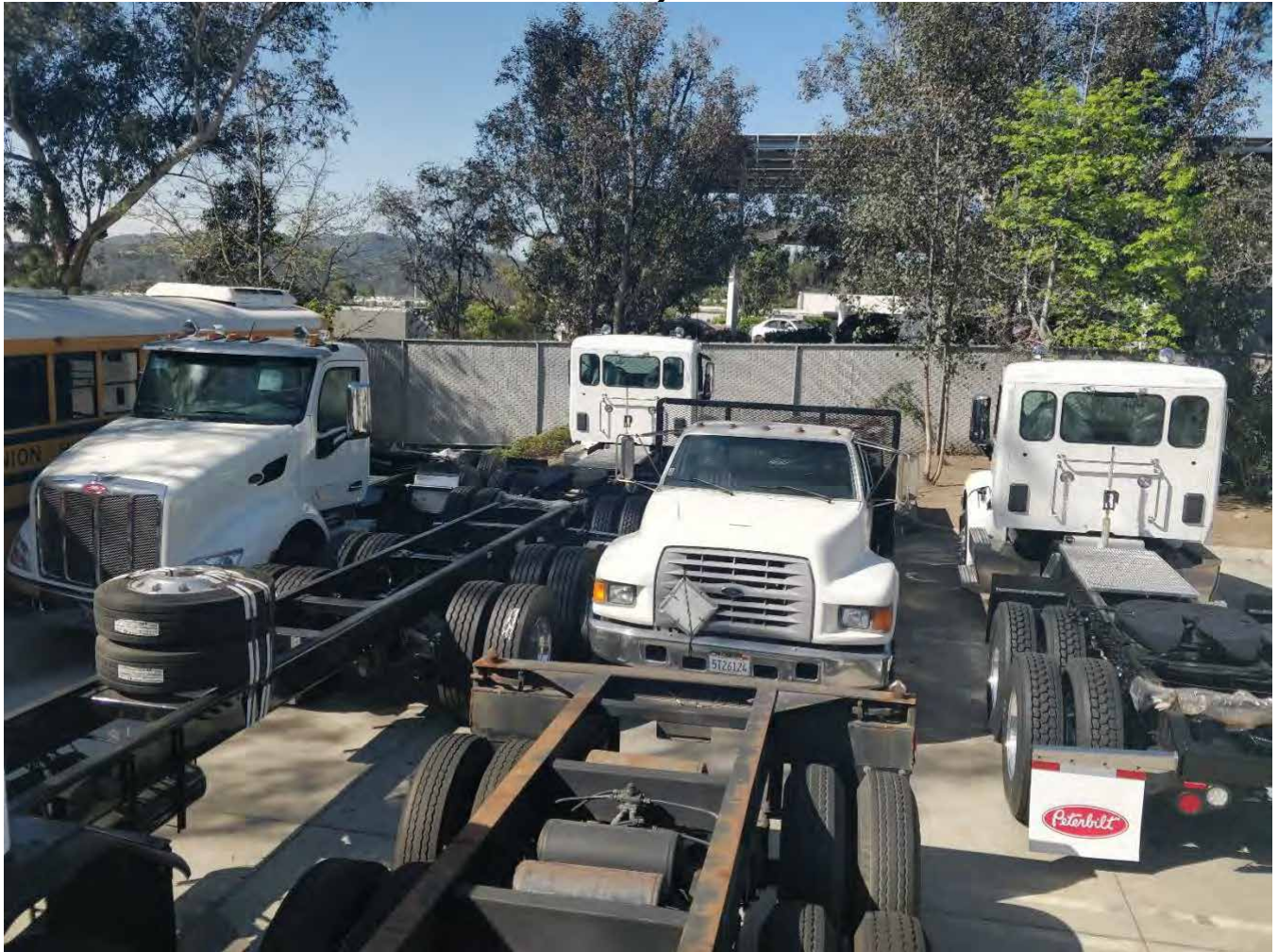

Photo of GGRF Peterbilt Rolling Chassis Stored at TransPower Credit: TransPower

Phase 2 subsystem assemblies completed 21 days late (See Figures 5,6, and 7). Delay is attributable to supplier adjusted delivery schedule for required components.

Figure 10: Heavy-Duty MDS Sub-system Installed in GGRF Project Truck

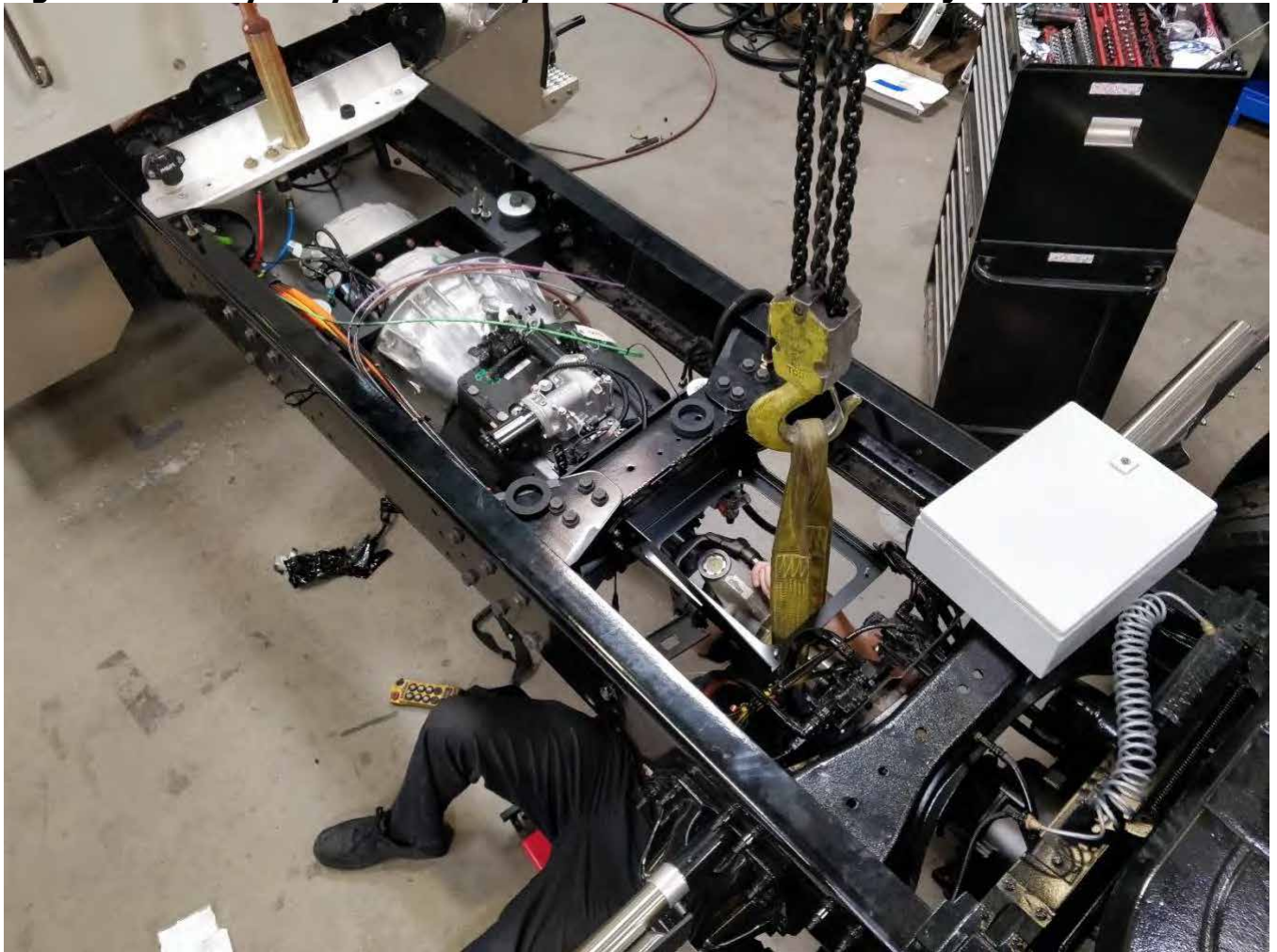

Photo of TransPower Technicians Installing Motive Drive System Sub-Assembly Credit: Transpower

Integration of trucks 5-8 occurred on schedule. Assembly of trucks five to eight occurred simultaneously at TransPower (See Figure 11)

Figure 11: GGRF Trucks 5 thru 8 in Integration Stalls



Photo of GGRF Trucks 5 through 8 During Build Process Credit: TransPower

Integration of trucks 9-12 completed 7 days early as a testament of Peterbilt and TransPower’s resolve to meet grant requirements.

The TransPower battery-electric powertrain was integrated into twelve Peterbilt 579 rolling chassis. Integration included design, scheduling, engineering planning, securing materials, integrating trucks, commissioning finished trucks.

Lessons Learned

Waiting for phase 1 trucks to begin deploying with fleets was not needed to identify design improvements. TransPower enhanced reliability and performance of Phase 1 and Phase 2 trucks with lessons learned in Phase 1 builds. Lessons from prior Transpower projects were applied to anticipated obstacles in Phase 1. Immediate improvements were applied to both Phase 1 and Phase 2 trucks with no need to wait for demonstration feedback.

The most significant lesson learned from prior projects led to the change of battery chemistry used in this project. Prior chemistries did not offer sufficient operating range to satisfy most truck fleets. Insufficient power density of other battery chemistries prompted the move NMC batteries.

Several improvements envisioned to occur in Phase 2 builds were pulled up and executed in Phase 1 trucks and they include:

- Changed coolant reservoir and mounting location for proper operation of coolant system
- Improved design in securing high-voltage cabling
- Development of new high voltage junction box to accommodate use of NMC batteries over LFP
- Redesigned regenerative braking designed to utilize Peterbilt OEM engine brake control switch

- Adoption of more reliable lower cost Battery Management System for NMC batteries
- Developed more accurate battery state of charge calculation software
- New DS200 Meltric ship-to-shore charge plug interface relocated to secure locking box on trucks
- Redesigned components to protect Powertrain Control Module and high voltage cables from UV damage and overheating
- Adopted floating transformer charging infrastructure to reduce noise on chassis that formally caused charging and drivability issues in prior versions of TransPower's electric trucks
- PCAS redesign for stability
- Improved MDS rear bracket
- Rolling Chassis Improvements to streamline operation and integration
 - Throttle pedal change for compatibility with Transpower electric drive system
 - Change to flange bolts from huck bolts
 - Predrilled bonding strap bolts
 - Backup alarm preinstalled and wired
 - PCS and MDS brackets preinstalled
 - Pedestal gear selector preinstalled and wired

Implementing lessons learned earlier than expected is attributable to an improved engineering change review process. The new process significantly increased the speed at which Transpower implemented design changes.

Past electrification of the drayage trucks initiated a series of new development programs:

Advanced integration of the TransPower Motive Drive System (MDS), Power Control and Accessory System (PCAS) and Energy Storage System (ESS) into the Peterbilt 579 Chassis.

Battery Choice

TransPower’s efforts to connect with mainstream battery suppliers supported the battery cell chemistry choice to use Nickel-Manganese-Cobalt (NMC). Typically, difficult for a startup to gain the attention of mainstream ESS suppliers, TransPower had been courting Automotive Energy Supply Corporation (AESC) Envision. Automotive Energy Supply Corporation supplied NMC cell technology built to Nissan OEM standards for the Peterbilt 579EVs of this project.

NMC power density to weight offered great support for reducing Energy Storage System (ESS) weight over previous Transpower ESS. More energy was carried on the GGRF ZEDT trucks than any prior electric trucks manufactured or modified by TransPower. TransPower designed connection bussing for their designed configuration.

Figure 12. Picture of the NMC ESS boxes installed on the chassis with four on each frame rail and total of eight boxes . Credit: TransPower LLC



NMC ESS, boxes, 6 8 on the frame

Figure 13: Assembled Battery Modules Prior to Installation into Frame Rail Cases



NMC Cell Assemblies Prior to Installation into 44kW Modules Credit: TransPower LLC

Figure 14 shows NMC battery assemblies of which 3 complete assemblies are combined per frame rail enclosure into a single 44kW module that can be mounted onto the frame rails of the Model 579ev as its ESS. Figure 15 shows the NMC TransPower system applied to the Peterbilt 579. This approach differs in that each box is a 400V 44kWh ESS string. The total ESS is then comprised of multiples of these individual strings. The trucks below are utilizing the frame rails for energy storage, have 6-8 of the strings for power range of 264-352kWh of energy with total tractor weight of only 19,420-21,500lb capable of up to 120 miles of range. The new ESS technology produced a vehicle that had 63% more energy storage, 71% more range, and weighed 5% less (see Figure 14 and 15).

Figure 14: TransPower NMC power Peterbilt 579 truck Climbing Pikes Peak CO and at Tradeshow



Two pictures, first of the TransPower NMC powered Peterbilt 579 tractor climbing Pikes Peak in CO and one of another 579EV staged at trade show. Credit: Peterbilt Inc

Figure 15: Peterbilt 579 with TransPower's Electric Drive System 8 strings of the NMC ESS system



A Peterbilt Model 579 truck 8 ESS strings installed, 4 on each frame rail

Credit: Peterbilt, Inc.

Remaining Integration

The ESS is the largest single subsystem installed on the 579EV. The completed chassis requires three more sub-systems. The Motive Drive System (MDS), Power Control and Accessory System (PCAS), Vehicle Integration Subsystem (VIS) complete the vehicle integration. All sub-system for the GGRF project trucks were installed at TransPower's facility. These integration tasks are described in the subsequent sections.

MDS

The Motive Drive System (MDS) (Figure 17) consists of a pair of:

- (2) 150KW electric motors
- (1) Eaton 10 speed gearbox with a controllable shift and high/low range actuator
- (1) Powertrain Control Module (PCM)
- (2) Motor inverters, one of which is the ICU and other an inverter only unit called the RS12.

The two motors are through shafted into the gearbox which is actuated by controlling the XY shifter and high/low range actuator. The gearbox has 10 available speeds but due to the wider torque band of electric machines only 5 are needed (3rd, 5th, 7th, 8th, and 9th). The PCM is mounted just reward of the gearbox. Due to space constraints, the inverters are physically mounted to the PCAS. The inverters can produce 150kW of continuous power with the ICU doubling as an on-board AC charger capable of 70kW. The PCM (not pictured) contains the controller and control hardware required to move the shift actuator and change the high/low range as required. Shifting is accomplished by the PCM. PCM reduces torque, shifts to neutral, commands motor speed, shifts into the next gear, and releases torque control back to the driver.

Figure 16: MDS, inverters, motors and gearbox installed

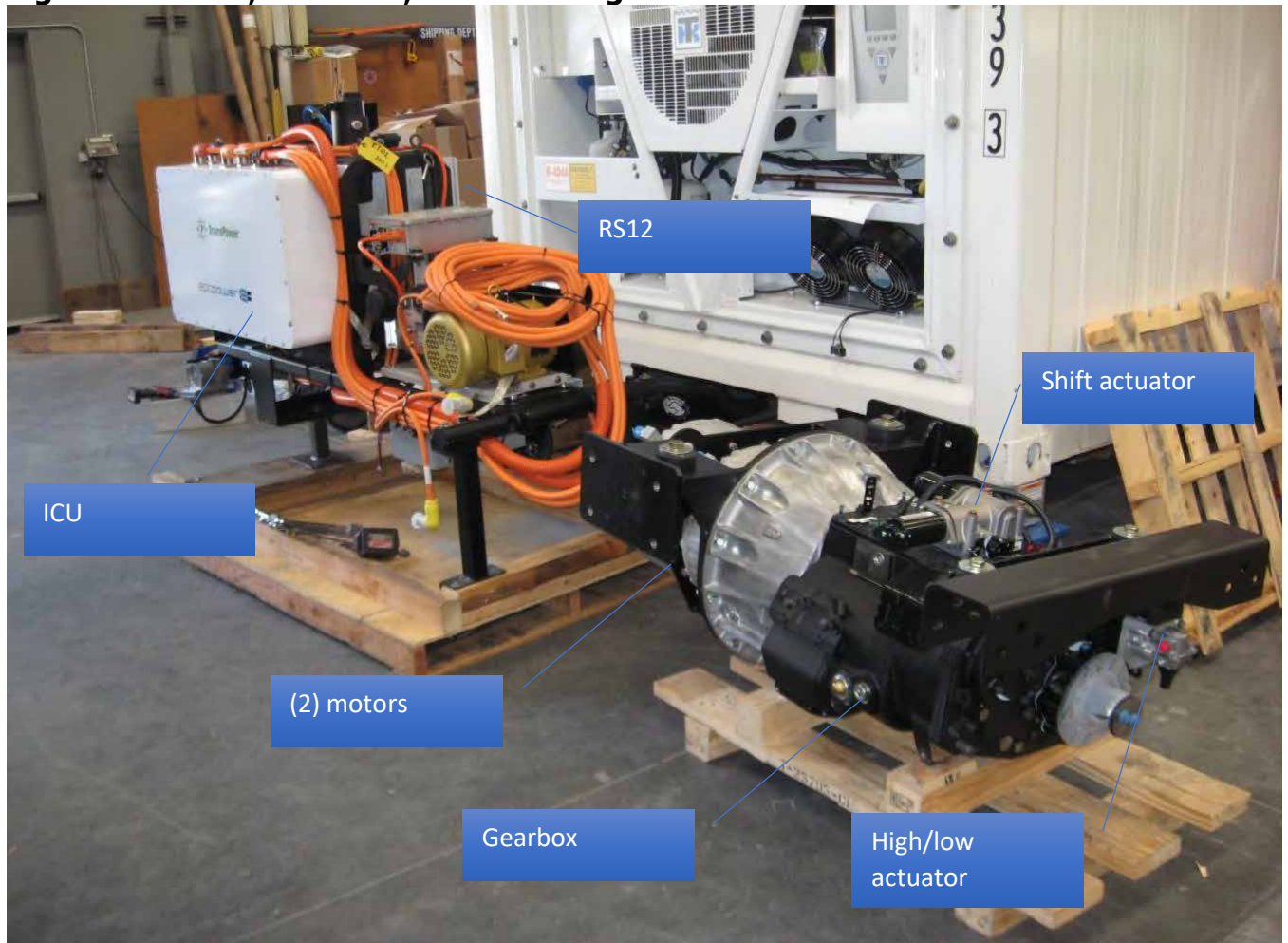

A PCAS on stand placed in front of an MDS in the same manner as they would be if installed in the vehicle. Credit: TransPower LLC

PCAS

The balance of the PCAS contains all what TransPower calls the Supervisory Control Module (SCM). SCM receives torque requests from the driver, displays information on dash, manages ESS, and controls various electrified accessories. Electrified accessories replace all the functions needed to operate a diesel truck. These components and functions include:

- SCM – controller and arbitrator of vehicle level controls. Sense torque requests to the PCM to initiate vehicle movement.
- BMS – Monitors the ESS cells, sends information to the SCM
- Coolant pumps – Cools the powertrain motors, power electronics, and ePTO motor
- DC-DC – replaces the function of the alternator providing 12V power to the vehicle via the HV DC bus

- Air Compressor – Provides air support for the service brake system
- Air Conditioning Compressor – replaces the engine driven compressor
- Cab Heater – replaces the engine supplied heated coolant for cab heat
- 12V Distribution hardware
- High voltage distribution hardware

All components are then installed as shown in Figure 17. The PCAS is located underneath the hood where the diesel engine would normally sit. The MDS gearbox and motors are mounted more rearward but ahead of the axle between the frame rails. The PCAS and MDS are connected via high voltage cable and low voltage wiring. The PCM (not pictured) is then mounted beyond the gearbox.

Figure 17: PCAS structures and Heavy-Duty MDS assemblies prior to integration into chassis





Figure 18. Photo of PCAS framework and Heavy Duty MDS before Integration Activities

Credit: TransPower LLC

The 579EV

At this point the truck chassis is now a running vehicle.

Figure 19: Completed GGRF 579EV Photo of Biagi Brothers GGRF ZEDT Truck



Error! Reference source not found.

Figure 20: GGRF ZEDT Peterbilt 579 Class 8 Tractor Rolling Chassis at Factory Photo of the PB 579 Rolling Chassis at Peterbilt's Denton, TX Manufacturing Plant.



Other Materials

Electric vehicles require EVSE (Electric Vehicle Supply Equipment) into which they plug when they need to charge. The TransPower EVSE is somewhat different from most in that it is an AC charging system capable of a 70kW charge rate. Home AC chargers are typically 3.3-7.2kW are known as Level 2 chargers and can go up to 19kW. DC fast chargers typically charge at 50kW. The TransPower/Meritor EVSE uses a 208V 3 Phase AC connection which can draw 194A of AC current. Supplying energy in a usable form to the truck employs a step-down transformer reducing commonly available 408V 3 phase to 208V power. Combined with safety protect hardware and a Meltric shore power plug (Figure 2121) a custom designed EVSE (Figure 2222) supports the fast AC charger (ICU) on board the vehicle.

Figure 21: Meltric brand shore power plug and receptacle



The Meltric supplier vehicle charge receptacle (Right) and charge cable plug (left).

Figure 22: Complete EVSE with transformer and charge control box



A TransPower EVSE with step down transformer and charging hardware box mounted to it. Credit: TransPower LLC

EVSE Installation Lessons Learned at Fleet Facilities

Installation of charging equipment proved to be a factor in overall delays deploying the 12 trucks built under the GGRF ZEDT grant. Each fleet facility or depot site needed to be reviewed for available voltage and current prior to EVSE installation. Trucking operations generally stay put in the same location for decades due to the local commercial zoning regulating their business. These decades old facilities pose challenges to deployment of battery electric Class 8 trucks.

All fleets experienced unplanned delays on charger installation with delays of 1-4 years. PepsiCo received truck 6 at their Hayward, CA plant and experienced one-year delay due permitting issues with the County of Alameda. AJR trucking was unable to secure permits for their charger over the course of 4 years/entire grant period. AJR was unable to participate in the project demonstration due to EVSE issues.

Los Angeles County fared far better in EVSEs installed than other participant counties. LA County installed 89% of EVSEs designated for GGRF project trucks.

A notable EVSE experience occurred at the project's top performer's depot site. Werner Enterprises in Fontana, CA operates in an older building and could not use the Transpower standard EVSE. Transpower engineering provided an effective work around to this unanticipated energy delivery situation. Transpower recommend a pass-through transformer rated to take the facility's 208D grid supply and convert it to the 208 Wye voltage needed. This approach facilitated the charging of truck 11 for one year before the charger no longer operated correctly. An investigation into energy available at the site revealed a significant change in the three phase A/C voltage coming from the grid. The change in voltage is believed to have originated from new commercial building construction around Werner's site. One of three legs was now "wild" signifying one leg was a significantly different voltage than the other two legs. Non-stepdown transformers cannot "clip" the "wild" leg to balance the voltage on the output side of the transformer. The pass-through transformer simply passed the high "wild" leg voltage from the Delta to Wye configuration. This pass-through a significantly higher voltage created a no-charge condition. The demonstration trucks require 208V Wye voltage withing 1% of 208V to meet charge protocol

requirements. The Wild leg pushed the voltage variation beyond the protocol limits causing charging faults to excite. This no-charge condition was resolved with a replacement 208v step down transformer.

Step down transformers allow the output voltage to be balanced through configuring internal transformer wiring any of three preset output levels. High input voltage of the “wild” was “clipped” down to within 1% of 208v with the stepdown transformer eliminating the no-charge condition.

AJR

AJR’s demonstration was severely hampered by one primary problem. A short time after the trucks were deployed, AJR moved to a different facility in Compton. The new facility did not have the requisite power supply needed for the trucks’ chargers. More specifically, in December 2018 AJR relocated both of their trucks and chargers to a new facility. After AJR reinstalled their charges at this new location, they kept receiving the same error code when attempting to charge. AJR installed the chargers on a breaker claiming to provide 480V, BYD technicians found that the actual voltage provided was only 284V. The voltage difference was causing the charging error. AJR engaged Southern California Edison (SCE) to determine the cause of the inadequate power. Although BYD made multiple site visits, including with SCE, BYD was not able to assist AJR in overcoming the problem. AJR had not resolved these issues as of December 31, 2021, so accumulated mileage for their two trucks was very low. AJR initiated an electrical infrastructure upgrade project. The project total cost of \$240,000 can deploy up to six DC fast chargers to support multiple battery electric trucks. AJR is working to finalize its permit with the City of Compton. Once the permits is approved completion of the EB+VBSEs installation is expected within 60 days.

Ease of Connecting Charger

TransPower’s EVSE utilized wide diameter cables to mitigate the heat accumulation in charge cables inherent to electric vehicle charging. Initial feedback from operators described the size of the cable to be a challenge for operators to utilize. Although with repeated use operators became accustomed to handling the charge cable. This feedback fully supports TransPower’s upcoming drayage truck design which will utilize CCS-1 Direct Current Fast (DC Fast) Charge technology. In upcoming redesigns of TransPower’s electric trucks the charge cable will be the same as those used for electric passenger vehicles.

Figure 23: Image of Operator Connecting Charge Cable to GGRF ZEDT Truck



Figure 24: Image of Transpower Electrically Driven Drayage Truck Charging at Public Charger in Sunnyvale, California



TransPower's Prototype Next Generation Drayage Truck Charging Using CCS-1 Charger in Sunnyvale, California

Commissioning

With a complete vehicle the process of commissioning is verifying various vehicle systems and features operate as one single unit. Commissioning includes ensuring all dash controls function, gauges read properly, the vehicle charges, diagnostic systems work, and a vehicle test drive. This mix of analog and more modern Controller Area Network (CAN) architecture made producing a final 579ev a complicated task.

Once high voltage was up and cab controls sorted, short driving and charging events commenced. However, the first vehicle exhibited signs of persistent Electro-magnetic Interference (EMI). This culminated in error frames on CAN buses which caused controllers to fault and go to their safe state. Symptoms included but were not limited to:

- ESS current measurement error
- CAN communication errors
- Shift actuator measurement error
- Speed sensor measurement error
- BMS cell voltage sensing measurement error

The grounding scheme is responsible for properly routing 12V current back to the battery. Bonding refers to the connection of all metallic structure available on the truck with appropriate cabling or straps. Bonding ensures components do not build up a voltage about one another. Bonding components allows electric components producing EMI route it to ground instead of potentially being induced into wiring. If not, bonded EMI radiates back out to the system causing deficient performance. After extensively improving and routing some low voltage wiring away from EMI sources, such as the powertrain motors, reliability quickly improved.

Validation Testing

The GGRF ZEDT were tested at the PACCAR (Peterbilt's mother company) Technical Center in Renton, WA in February 2019. Peterbilt tested the Transpower driven GGRF ZEDT 579ev for observable deficiencies in driveline vibration, interior noise, or steering performance. No performance deficiencies were observed during testing. Driveline vibration was acceptable. Steering was comparable or better than a diesel truck. Interior noise was well under the recommended not to exceed levels.

Dynamometer and Temperature Testing (DTT)

September 17th, 2019 the GGRF ZEDT 579e entered DTT to complete all planned testing. Planned testing was conducted to understand the baseline capability of the GGRF 579EV compared to diesel counterparts. During DDT drive cycle/range tests and maximum charge while in a regen tests were completed. The test truck was evaluated performance over a grade. Each test was performed at -4F, 70F and 120F. The test truck was able to maintain 65 mph in 120F. The GGRF ZEDT truck reached its top speed and showed fully capable in the heat. It performed very well with pulling regen torque as it approached maximum state of charge (SOC). The test truck performed in a linear fashion at all temperatures and then reached a nominal regen percentage once it reached maximum SOC. After reaching maximum SOC the test truck maintained the amount of regen it took to maintain parasitic losses.

Tests were completed at each temperature set point. The 70F test had no problems. The -4-degree test performed very well. There was an observable power de-rate of around 15% in the cold and was noted as nominal. During hot testing (120F) the truck's safety system reduced maximum available drive torque to the wheels. Drive torque went from 87% of maximum motor torque allowed to about 50% in hot testing. The change in performance during the heat test appeared to be due to the batteries

approaching their maximum operating temperature. The batteries used in the GGRF 579EV builds did not have an onboard cooling system.

Figure 25: GGRF ZEDT During CCD Testing



Figure 26: GGRF ZEDT During CCD Testing



Figure 1: GGRF ZEDT Peterbilt 579ev with Transpower Electric Drive System



Prototype 579ev Connected to Test Load at PACCAR Technical Center Renton, WA

Credit: PACCAR

Peterbilt and TransPower used the new rolling chassis approach vs. removing diesel powertrain from outset of this program. Using the new rolling chassis recategorized TransPower from a its traditional role as a Modifier to a Manufacturer. Recategorization fell under the National Highway Transportation Safety Administration's (NHTSA's) regulatory framework. Modifiers are only required not to reduce a vehicle's Federal Motor Vehicle Safety Standards. Manufacturers much assess and be prepared to prove the changes maintain FVMSS requirements and register that vehicle with NHTSA stating as much. Twelve project trucks were built in 2018 with deployment without tractions control set for 2019. New regulations over Roll Stability on Class 8 tractors released in 2019 forced a temporary downing of the project trucks. Transpower, Peterbilt, and Bendix integrated roll stability system into all twelve trucks through a combination software and parts. Updates were performed through a combination of customer-site upfits and manufacturing upfits with new Bendix controllers, wiring, yaw sensors, and brake valves. TransPower changed the powertrain mass distribution of the NHTSA certified 579. TransPower deemed it necessary to have the vehicle recertified to justify the claim that the vehicle was FMVSS compliant. To accomplish this, two things are required.

ABS supplier Bendix must test the vehicle and supply a test report supporting the application of their system with TransPower.

1. ABS supplier Bendix must test the vehicle and supply a test report supporting the application of their system with TransPower.
2. An independent testing entity, Link Engineer, perform the prescribed test and supply a report of results.

With these two reports, TransPower could then claim due diligence was done and register the vehicles with NHTSA as in-compliance.

CHAPTER 3:

On-Road Demonstration

Overview

The Peterbilt GGRF ZEDT project was executed in two phases. Phase one consisted of trucks 1-4 and phase two consisted of trucks 5-12. All 12 trucks deployed into real-world fleets disbursed throughout California. The wide variety of use cases proved technology adoption limitations, best use cases, and reliability of current electric powertrain.

Key Challenges

First, ease of installation of EVSE systems at the various fleet sites was of mixed difficulty. The range spanned from easily permitted/installed to permitting prohibiting installation. Some fleet sites only saw delays while others could not participate entirely due to electrical permitting complications.

Second, resistance to high voltage training to support fleets in service of electric trucks played a key role in constraining mileage accumulation. Training developed by Transpower was delivered where allowed. Transpower also provided information on high voltage certification training provided by other companies. Not all fleets desired high voltage training due to new safety concerns with electric trucks.

Third, low buy-in to high voltage training created a service environment that depended fully on the advanced technology technicians employed by Transpower. The overwhelming theme observed during the demonstration period was one of all issues no matter the significance were electric truck problems. This reluctance from fleet technicians to work on or near the electric truck created excessive downtimes. Many downtime events that impacted reliability perception were traced back to operator-fleet technician level deficiencies like discharged 12v batteries.

Fourth, operators varied in acceptance of the technology and willingness to operate the projects electric trucks. As with any cutting-edge technology there are nuance characteristics to accept. Operators with rotating driver staff performed far less successfully than those using a dedicated single driver. Fleet operator business models impacted truck usage and acceptance. More study into how electric vehicles fit into various fleet business models is needed to identify best use fleets and organizations. Repetitive use of the vehicle was key to the operator's understanding of the technology and comfort operating the truck.

Fifth, changes in the Federal Class 8 tractor regulatory environment rolled out at the outset of the demonstration period. The change in federal regulation related to roll stability from MY2018 to MY2019 created a delay in the actual use of project trucks. Mileage accumulation was delayed for six months while Transpower, Peterbilt, and Bendix built roll stability into TransPower's control system design.

Sixth, powertrain component quality and reliability posed a key challenge during the demonstration. Designed battery enclosures were found to be manufactured out of specification by TransPower's originally contracted supplier. Insufficient sealing of the majority of originally purchased battery module enclosures was identified early in the demonstration. Transpower changed suppliers and performed field inspections of the deployed battery enclosures. Battery enclosures found with insufficient seal

were immediately replaced with enclosure passing new seal checks developed to mitigate the sealing issue. Inverter-Charge-Units (ICU) used in driving electric motors proved below TransPower’s standards for on road applications. The inverters sourced for this project were discontinued by the supplier during the demonstration. The discontinuance created high cost for replacement parts needed to address the ICU related deficiencies observed during the demonstration. Shifting concerns were noted with investigations ongoing until the end of the project. Most noted but not fully quantified contributor to shifting concerns were identified electromagnetic interference, inverter robustness, road conditions, and operator driving habits. Environmentally sealing of other automotive rated sourced components and purpose-built parts proved to be another concern during the demonstration. Transpower identified proper design orientation of parts both sourced and made to use in subsequent designs iterations of its electric powertrain.

The project team and collaborators were able to accomplish 125,300 miles as of January 2022 between the twelve trucks. All twelve trucks were successfully commissioned and operated with demonstration fleets. The actual performance of 12 units varied by fleet and is reflective of the variations in load, terrain, and driving habits. An eight-month analysis of average fleet efficiency by participant from Jan-Aug 2021 is seen in Table 1.

Table 1 Average Truck Efficiencies

	Truck	Average Efficiency kWh/Mile
TTSI	1	1.96
BAE	2	1.91
NFI/Benore	3	2.55
Estes	4	2.19
SCE	5	1.84
PepsiCo	6	2.36
Biagi	7	2.52
Harris Ranch	8	1.60
Oak Harbor	9	2.33
Daylight	10	2.14
Werner	11	2.25
AJR	12	2.01

Table of Average kWh per mile Per Fleet Credit: TransPower

Of the 125,300 total EV miles, each fleet varied in mileage accumulation. Variations in driver availability, infrastructure, perceived reliability, range required for use, field failures, updates, and repairs impacted each fleet demonstrators use. Cumulative project mileage and calendar year Quarter 4 by fleet/user is shown in Table 2

Table 2. Total Mileage Accumulation

FLEET	Truck #	VIN	Total Mileage as of March 2022
TTSI	1	4T9FABPD6KA072001	21,290
LADWP/BAE Systems	2	4T9FABND4KA072002	11,043
CMI/NFI/Benore/Denton, TX(Peterbilt)	3	4T9FABND6KA072003	3,143
ESTES Express	4	4T9FABPD1KA072004	17,840
So Cal Edison/Meritor	5	4T9FABNDXKA072005	8,485
PepsiCo/Meritor	6	4T9FABND1KA072006	3,610
Biagi Brothers	7	4T9FABND3KA072007	6,161
Harris Ranch/Meritor	8	4T9FABND5KA072008	11,686
AJR (swapped to Oak Harbor)/Meritor	9	4T9FABPD0KA072009	4,034
Daylight/Meritor	10	4T9FABPD7KA072010	6,428
Werner	11	4T9FABPD9KA072011	24,203
Oak Harbor/Meritor/PepsiCo	12	4T9FABPD0KA072012	9,402
TOTAL			125,300

CHAPTER 4:

Lessons and Improvements

Key lessons and future improvements

From the manufacturer and integrator's perspective, Peterbilt and TransPower learned many lessons from the demonstration of the GGRF ZEDT project refuse trucks. The key lessons were:

- Identify new or challenging operational requirements by doing more customer operational research, riding along on routes, try to truly understand how the vehicle is used.
- Take FMVSS into consideration up front. If the rolling chassis route is chosen, write an FMVSS task into the proposal.
- Better understand the energy consumption of the fleet for adequately supplying enough energy at outset of demonstration for each fleet's needs.

Commercialization and Design Improvements

Based on this project and other projects, TransPower/Meritor was awarded a non-exclusive supplier agreement with PACCAR for the Peterbilt and Kenworth brands. Meritor was selected to supply the EV power kit for the 579 tractor, T680 tractor and 520EV refuse truck.

Table 3 shows key specifications between the first and second generation "ElecTruck" truck . Second generation trucks are entering volume production March 2022.

Table 3: Peterbilt Model 579 EV GGRF ZEDT Phase 1 and Phase 2 Truck First vs. Commercial Truck Comparison

Details and Specifications	First Generation 579 EV (GGRF ZEDT Trucks)	Second Generation 579 EV (Production-Ready)
Model Year	2018	2022
Electric System	Remote mount	Integrated tandem eAxle
Battery Capacity	264-352 kWh	396 kWh
Usable Battery Capacity	246 kWh (80% usable)	356 kWh (90% usable)
Battery Chemistry	Lithium Nickel Manganese Cobalt	Lithium Iron Phosphate
Peak Power	320kW	500 kW
Torque	1,348 Nm	2,200Nm
Estimated Range	90 miles loaded	120 miles loaded
EVSE Plug	70kW TransPower Meltric, AC on-board charging	90kW-180kW CCS-1 standard, DC Fast Charging capable
Final Vehicle Manufacturer	TransPower	PACCAR
Power Controls & Accessories	TransPower	TransPower
Dealer & Maintenance	TransPower	Peterbilt Dealerships (i.e., Coast Counties Peterbilt, Golden State Peterbilt, Rush Truck Centers)

Table of Differences Between Project Trucks and Commercially Available Trucks Credit: TransPower LLC

CHAPTER 5: Conclusion

The average kWh/mile efficiencies and total mileage accumulation during the GGRF ZEDT project was key to commercialization of TransPower electric powertrain systems. The same is true for Peterbilt’s commercialization of electric drayage trucks.

Peterbilt listed the 579 EV on the California HVIP (Hybrid and Zero-Emission Voucher Incentive Project) Figure 28.

Figure 28 HVIP Voucher for Peterbilt 579EV Available

The screenshot shows the California HVIP website interface. At the top left is the HVIP logo. Navigation links for Home, Vehicles, and Purchasers are visible. Search filters include OEM (2), Vehicle Size, Vehicle Type, and Technology Type. A 'Clear' button is present. Two OEM filters are active: Kenworth and Peterbilt. Below the filters, it states '2 vehicles found' and 'Sort by Name'. Two vehicle cards are displayed:

- Kenworth T680E Battery Electric Truck**
 - 396 kWh
 - Battery Electric
 - Class 8
 - Incentive Amount: **\$120,000**
 - Type: **New**
- Peterbilt 579 Battery Electric Truck**
 - 396 kWh
 - Battery Electric
 - Class 8
 - Incentive Amount: **\$120,000**
 - Type: **New**

Image of PACCAR’s 579ev and T680 Electric Drayage Trucks from HVIP Website Credit: HVIP

The HVIP program offers point-of-sale vouchers at \$120,000 for battery-electric drayage trucks. Two Class 8 Heavy Duty Tractors using the Transpower/Meritor derived from the GGRF project are available for incentives as of Mar 2022.

investment from the California Air Resources Board and Southern California Air Quality District led to further industry investments in electric drayage trucks. Further investment in battery electric trucks created more jobs in California. We anticipate job creation in engineering, technician support, at dealerships and manufacturers as a result of GGRF truck demonstrations.



Air Quality Improvement Program Green House Gas Reduction Fund

Project 17244: Near Zero Emission Drayage Truck Demonstration Project

Prepared for: South Coast Air Quality Management District
and California Air Resources Board

Prepared by: Kenworth Truck Company
Kenworth Research and Development Center

Final Report: April 2022





Kenworth Truck Company

Research & Development Center

485 Houser Way North

Renton, WA 98057

Stan W. DeLizo

Research Engineering Manager

(425) 430-5747

stan.delizo@paccar.com

www.kenworth.com

Funding Source Acknowledgements

South Coast Air Quality Management District

21865 Copley Drive

Diamond Bar, CA 91765

Seungbum Ha

Project Manager

Dana Foist

Contractor, Technology Demonstration

Patricia Kwon

Program Supervisor, Technology Demonstration

California Air Resources Board

1001 I Street

Sacramento, CA 95814

Earl Landberg

Project Manager





FUNDING SOURCES ACKNOWLEDGEMENT

South Coast Air Quality Management District (SCAQMD)

South Coast AQMD is the regulatory agency responsible for improving air quality for large areas of Los Angeles, Orange County, Riverside and San Bernardino counties, including the Coachella Valley. The region is home to more than 17 million people—about half the population of the entire state of California.

South Coast AQMD is responsible for controlling emissions primarily from stationary sources of air pollution. These can include anything from large power plants and refineries to the corner gas station. There are about 28,400 such businesses operating under South Coast AQMD permits. Many consumer products are also considered stationary sources; these include house paint, furniture varnish, and thousands of products containing solvents that evaporate into the air. About 25% of this area's ozone-forming air pollution comes from stationary sources, both businesses and residences. The other 75% comes from mobile sources—mainly cars, trucks, and buses, but also construction equipment, ships, trains, and airplanes. Emission standards for mobile sources are established by state or federal agencies, such as the California Air Resources Board and the U.S. Environmental Protection Agency, rather than by local agencies such as the South Coast AQMD.

California Air Resources Board (CARB)

CARB is charged with protecting the public from the harmful effects of air pollution and developing programs and actions to fight climate change. From requirements for clean cars and fuels to adopting innovative solutions to reduce greenhouse gas emissions, California has pioneered a range of effective approaches that have set the standard for effective air and climate programs for the nation, and the world.

Reducing air pollution and protecting public health guide CARB's actions. Their role is to:

- Set the state's air quality standards at levels that protect those at greatest risk – children, older adults and people with lung and heart disease
- Identify pollutants that pose the greatest health risks, such as diesel exhaust particles, benzene in gasoline and formaldehyde in consumer products
- Measure our progress in reducing pollutants utilizing the nation's most extensive air monitoring network
- Verify automakers' emissions compliance at CARB's renowned Haagen-Smit Laboratory in El Monte
- Research the causes and effects of air pollution problems – and potential solutions – using the best available science and technology
- Study the costs and benefits of pollution controls, paying particular attention to individuals and communities most at risk
- Lead California's efforts to reduce climate-changing emissions through measures that promote a more energy-efficient and resilient economy

The Kenworth team acknowledges their commitment to and appreciates the opportunity to build these prototype vehicles and explore the limits of understanding this funding has offered as we continue to learn about this technology.





PREFACE

CARB Greenhouse Gas Reduction Fund (GGRF) Zero Emission Drayage Truck Demonstration Project (ZEDT) is funded through a FY 2014-15 grant for the Air Quality Improvement Program and Low Carbon Transportation Greenhouse Gas Reduction Fund Investments. The GGRF ZEDT project is part of California Climate Investments (CCI), a statewide initiative that puts billions of Cap-and-Trade dollars to work reducing greenhouse gas emissions, strengthening the economy, and improving public health and the environment – particularly in disadvantaged communities. The GGRF ZEDT project is funded through CARB grant G14-LCTI-09 to deploy 44 pre-commercial zero and near-zero emission Class 8 battery electric, CNG and diesel hybrid electric drayage trucks along with supporting infrastructure will be operated in revenue service throughout the state at the Ports of Los Angeles, Long Beach, San Diego, and Oakland in the South Coast AQMD, Bay Area AQMD, San Joaquin Valley APCD, and San Diego APCD jurisdictions.

Keywords: AQMD, CARB, GGRF, AQIP, CCI, ZEDT, hybrid, heavy truck, CNG, alternative fuel, class 8.

Please use the following citation for this report:

DeLizo, Stan, Kenworth Truck Company; 2022; *Kenworth Near Zero Emission Drayage Truck Demonstration Project*; South Coast Air Quality Management District, SCAQMD Project Number 17244.





ACKNOWLEDGEMENTS

This project could not have been completed without the selfless dedicated support from the professionals working at the Kenworth R&D Center in Renton WA. The team noted below spent countless hours agonizing over unforeseen problems, worked with unreasonable demands from their time and developed a product worthy of their efforts. Please recognize and acknowledge their effort.

Brandon Delgado: Electrical and Controls Engineer focused on Electrical System Design, Software and Communication Design and Development, Problem Solving at all levels of the vehicle electrical, communication, software, and controls.

Joseph Tarp: Development Engineering Manager for Cooling System, Lubrication System and Chassis Build

Stephen Oi: Electrical Engineer Chassis Harness Design and Build, Electrical System Compatibility, Custom Wiring and Chassis Build

Sam Trandem: Electrical Engineer focused on high voltage battery selection, design, assembly, and integration.

Davis Chang: Mechanical Engineer Chassis Design and Layout, Air and Cooling System Development and Chassis Build, Problem Solving as required during final assembly, startup, and test.

Brian Hannon: Mechanical Engineer thermal systems design, build and testing.

Brian Lindgren: R&D Center Manager providing team Leadership, Product Design Guidance, Budget and Resource Negotiations, General Support and Incentives as required.

Outstanding technical support from Walt Benz, Mike DeVore, Scott Schloemer, Tristan Lawson, and Bob Gurney for solving all types of issues identified throughout the project.

PACCAR India Technical Center team support, with special recognition to Shubha Sharma, Titiksha Paranjape, Abhilash Puranik, Sameer Swain and Ryan Pizzirusso working at many levels to resolve product design and system controls issues as they were identified.

Kenworth would also like to recognize and commend TTSI for their support specifically to Tony Williamson, Vic La Rosa Jr., Ryan Sickles and Alfredo Villareal.

The support from the rest of the Kenworth organization (past and present); direct and indirect suppliers and anyone who although not mentioned specifically are not forgotten.





TABLE OF CONTENTS

Contents

Funding sources acknowledgement	3
Preface	4
ACKNOWLEDGEMENTS.....	5
Table of Contents.....	6
Glossary.....	8
ABSTRACT.....	9
Executive summary.....	10
Introduction	11
Phase 1: Baseline Hybrid Electric Vehicles	11
Phase 2: Stop Work Issued	20
Field Demonstration Discussion	20
Support Activities: Beyond the Vehicle	22
Comments and Conclusions	23
Performance	26
Chassis Specifications	26
Appendix:	27
Intro to Electrical Components.....	27
Intro to Propulsion System	27
Intro to State of Charge & Fuel.....	28
Power Distribution.....	29
Custom changes to the T680 Cab	30
Emergency-Stop Button (E-Stop).....	30
B-Panel Display	31
Low Voltage Battery Disconnect Switch	32
Mountain Mode Switch and EV Mode Switch.....	33
Data Logger.....	33
Right Hand Stalk.....	34
The HVPD (High Voltage Power Distribution) Unit.....	34
External Low Voltage Power Distribution Switch	35
Safety	36





Project 17244: Final Report

HV Introduction and Training36

Working on High Voltage areas of the truck36

Fault Matrix.....37

Deliverables Summary Report38

Attachment 1: Marketing Report40

Attachment 2: Labor Report.....40

Attachment 3: Lessons Learned Report41

Attachment 4: Performance Matrix41





GLOSSARY

ACTM	Alternating Current Traction Motor. The main propulsion motor of the truck, it is located under the CNG storage system and between the chassis rails.
AFV	Alternative Fuel Vehicle (AFV)
ARFVTP	Alternative and Renewable Fuels and Vehicle Technology Program
ASTM	American Society for Testing and Materials
CEC	California Energy Commission
CNG	Compressed Natural Gas. The fuel used to power the range extender motor.
DGE	Diesel Gallon Equivalents
ESS	Electrical Storage System. The main propulsion high voltage battery packs.
EV MODE	Electric Vehicle mode.
e-Motor	Electric Motor
GENSET	Engine and Generator set used to produce electricity
GHG	Greenhouse gas
HECT	Hybrid Electric Cargo Transport, near zero emission hybrid. 1.0 is the initial design, 2.1-2.2 are subsequent versions in this project.
HV	High Voltage. Any electrical system or cable that handles more than 50V. HV cables are colored orange.
HVAC	Heating, Ventilation and Air Conditioning
HVIL	High Voltage Interlock Loop. Continuous electrical loop throughout the vehicle, routed through the main electrical devices and is intended to shut down high voltage devices when open or serviced. Intended as a safety system.
HVPD	High Voltage Power Distribution Unit. Otherwise known as HVPD. This is the main high voltage distribution for the truck.
KW	Kenworth Truck Company
OEM	Original Equipment Manufacturer
PDE	Power Distribution Element (a component of the HVPD)
SHEV	Serial Hybrid Electric Vehicle
SOC	State of Charge. The level of electrical storage in the ESS, stated as a percentage.
US EPA	United States Environmental Protection Agency





ABSTRACT

The interest in hybrid electric vehicles using alternative fuels in heavy truck applications continues to grow. This project developed and demonstrated a class 8 hybrid electric heavy truck tractor powered by a stock natural gas fueled internal combustion engine purposely undersized for this application. The research project used forward-looking simulation models and acquired field data to modify power management strategies for hybrid type vehicles in commercial heavy haul applications.

Research was conducted to identify suppliers with heavy truck and hybrid vehicle applications, leverage technology developed to date and integrate the components onto a chassis with the shortest possible wheelbase. The short wheelbase remains the most challenging to package hybrid specific components, continued success with this layout allows design to be applicable to a broad range of heavy truck chassis designs of various wheelbases and applications.

The type of hybrid used in this demonstration is a series hybrid, to clarify, the engine is mechanically decoupled from the drive train. The compressed natural gas engine is coupled to a generator, which then supplies electric power either directly to the power train or indirectly through an energy storage and retrieval system. The engine and generator output were designed to compete with appropriately sized diesel engines used in this same application. A hybrid drive assembly was powered by the engine and generator plus the energy storage system and power was managed by a programmable power distribution box and a vehicle control system.

Once assembled and site tested, the class 8 compressed natural gas engine on a serial hybrid electric vehicle, through simulation, is predicted to have better fuel economy in pickup and delivery applications and should compete well in short/regional haul applications. Further testing is required to validate simulation results.





Executive summary

The goal of this project was to determine the technical and economic feasibility of replacing mechanical systems used on diesel engine technology for Class 8 truck tractors with an engine and generator set (genset) fueled by natural gas in a hybrid electric vehicle. The vehicle also has a large high voltage (HV) battery bank for zero emission operations and to supplement engine output to the electric drive system.

A simulation model was developed to emulate real-world conditions. Data was gathered from customer routes in southern California near the Ports of Los Angeles and Long Beach. The routes selected included but were not limited to Pickup & Delivery, Regional Haul to the Inland Empire and local drayage operations around terminal island. These data were used as the input source for the model, enabling the model to predict the performance of various hybrid and battery configurations and components.

Based on these predictions, a Series Hybrid Electric Vehicle (SHEV) was designed around a Kenworth T680 day cab, components were sourced, and the vehicle was modified, assembled, and tested.

The completed vehicle was tested on a dynamometer measuring power and torque at the wheels. Using these dynamometer data in the simulation model, the vehicle was shown to achieve nearly 30% fuel economy improvement in Pickup & Delivery applications, but only very small gains in Regional Haul applications. These results closely match initial predictions made from simulation.

The simulation model created for this project was proven to be quite accurate. This tool can be used for choosing hybrid designs and components in future truck designs. It also showed that a hybrid vehicle must be optimized to the specific applications and route profiles to achieve desired operational and fuel economy gains.

The hybrid genset with large capacity HV batteries was shown to be technically feasible in these applications, although not yet reliable enough for mass production. Efficiency and environmental gains were nearly as predicted.

Additional testing is recommended to further evaluate the environmental benefits of this truck design. Development of the genset hybrid vehicle design should continue, with a focus on improving reliability, reducing complexity, and lowering cost.





Introduction

In response to the challenge and goal of reducing emissions in the ports by CARB and SCAQMD, this project was proposed to demonstrate four Class 8 plug-in hybrid electric trucks with zero emission operation capability in revenue drayage service from the ports of Los Angeles and Long Beach. Kenworth believed that a natural gas series hybrid could be a cost-effective bridge vehicle to the eventual implementation of full electric or zero emission hybrid electric vehicles in drayage applications. Kenworth proposed the development of four natural gas series hybrids to prove this possibility.

The project developed and demonstrated a class 8 hybrid electric tractor powered by a small, existing production low emissions natural gas fueled internal combustion engine. The vehicles were placed in commercial service with TTSI to determine if a CNG hybrid could significantly improve fuel economy in a drayage and regional haul application. The effects of improved fuel economy on local population are a reduction in global climate emissions and greenhouse gases. Multiple reports suggest that the San Joaquin Valley and Southern California, on occasion, has poor air quality both in terms of smog and particulate pollution. Efforts to reduce pollution is the motivation from the funding sources.

To the benefit of the environment, the Southern California region has set very difficult emissions targets and has funded opportunities like these to develop and break through the technical barriers to allow automotive and bus products to migrate quickly and seamlessly into the heavy-duty commercial vehicle industry. To meet these aggressive goals OEM's and end users must build, deploy, and operate vehicle architectures pushing the limits of available technology to meet the state emissions goals.

Despite the challenges, conversion of drayage fleets to zero-emission propulsion will provide immeasurable benefits to local communities, while significantly reducing GHG emissions. However, making this transition faces two serious challenges. The first is a combination of meeting operational needs and proving technology readiness, and the second is manufacturability and serviceability of a commercially affordable vehicle. This report provides an overview of the achievements toward these goals and the challenges and associated lessons learned through the construction, testing and completion of this project.

Phase 1: Baseline Hybrid Electric Vehicles

The design for this fleet was like the previously demonstrated Kenworth vehicle HECT (DE-FOA-0001106). Suppliers were tasked early to leverage the information gathered from the HECT project and to improve product efficiency and reliability for this build. Therefore, many of the suppliers from earlier projects were selected to supply parts for this project. The lessons learned from earlier projects were used to improve the technical specifications of products to be used on this vehicle.

The HECT program lessons learned recommended that to have successful and precise control of the vehicle systems, integration and control the vehicle to down to the component level was required. The power management strategy must be controlled by the OEM to ensure the precise interoperability of each component to achieve the reliability and efficiencies required to become competitive in the commercial electric vehicle market. Without control of the final arbitration vehicle performance couldn't





Project 17244: Final Report

improve without a supplier's approval and support. The project aimed to increase more of the vehicle operations under the Kenworth development process.

Based on results from the previous HECT program, Kenworth chose to use the same natural gas engine and generator, drive motor and main transmission. The HV battery design was refined to reduce the amount of time required to install, test, and repair the battery modules. The team developed a new set of energy storage, charging and discharging requirements to selectively improve battery assembly and integration. These requirements were competitively quoted and the HV battery supplier was selected. Previous vehicles also had too many connectors resulting in a significant number of opportunities for failure. This was addressed through the specification and selection of auxiliary motors, inverters, and controllers.

The design changes reduced the number of HV battery modules, improved access to the individual and system battery monitoring systems and reduced the number of custom brackets required to install the batteries to the chassis. Regarding the auxiliaries, the team was pressed to select a common motor, controller, and inverter for each of the accessories. The team then worked with the motor, controller, and inverter supplier to fully integrate the three components into an entity with a single LV connector and single HV connector, thus reducing the opportunities for failure and simplifying the assembly. The parts met performance requirements but as they were one-of-a-kind prototypes, reliability issues arose, and repeated manufacturing and supplier assembly failures limited time in operation.

In addition to the design changes driven by the HECT program field test results, Kenworth identified opportunities to further integrate subsystems, revise design parameters to offset reliability issues and modified power management strategies between the power plant and stored energy systems for improved fuel economy.

The part design changes, unfortunately were appearing throughout the HECT project and were difficult to resolve in process and apply to this project. In some cases, the sub-component designs had to change due to supplier mergers, acquisitions or dropping out of the commercial EV business. Other design changes were driven by suppliers simply wanting to challenge the end user requirements and supply only products as they were currently produced and sold. Many rounds of negotiations and directives were applied to ensure final product would perform to the design intent.

On a positive note, the design directions circulated to the supply base were received and considered practical, suppliers were receiving similar requests for the improved designs from other sources and their assembly and test processes stood to benefit from the improvements. Unfortunately, the amount of time to design and build the auxiliaries, was extremely short and design tests were held in parallel with deliveries to hold to schedule. In many cases as the issues and failures were being resolved, suppliers would fix parts used on this project and they were swapped out during the demonstration.

As an example, the incompatibility between the generator supplier and the generator controller was a significant issue. The parts were received but did not work together. The control strategy between the two components were not compatible and neither company informed Kenworth that this might be an issue, nor did they care to compromise their designs. The issue was that the generator is built without a resolver or digital position sensor and the generator supplier used proprietary information to manage the generator operation. The component required to make a generator perform is the controller. The controller selected requires a resolver or digital position sensor to manage the generator operation.

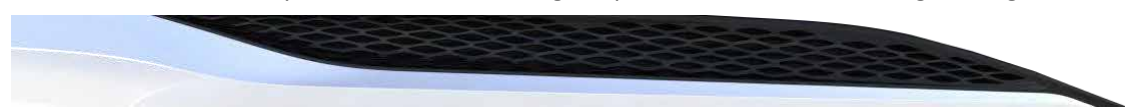



Project 17244: Final Report

Kenworth researched and found a resolver from a third party for the generator, modified the generator shaft to mount the resolver, and successfully tested it in cooperation with the controller supplier.

Another issue was the initial design of the heavy-duty transmission. The supplier developed a transmission with more gears than was necessary. Their developers suggested that hybrids needed at least six gears, and the Kenworth analysis suggested only three were required. After many months comparing analysis results, a mutually agreed to product was defined and the supplier purpose built a transmission with four gears.

However, this did not completely resolve the transmission issues. Although commercial vehicle suppliers have years of experience designing products for standard diesel products the design for electric vehicles is new. The new transmissions had software issues that made their performance less than acceptable. Specifically, the shift duration was excessive and wasn't as smooth as the previous product. Kenworth spent a significant amount of time working with the supplier to reduce the shift cycle time to a short enough period and under the correct electric motor load conditions to remove the clutch while maintaining applied torque. With this accomplishment the transmission and e-motors were fully integrated into the vehicle power management system.

In a somewhat related issue was the transmission supplier's wish to own final arbitration of the shift. Kenworth wanted the transmission control unit to have a secondary relationship to the vehicle controller and the transmission supplier wanted the vehicle control to be secondary. The transmission supplier struggled to release final arbitration control to the vehicle to protect their assembly from misuse and Kenworth required a condition where the transmission could be sacrificed to ensure the vehicle could be moved to a safe environment. A mutually acceptable decision between the vehicle state and transmission control was identified and software was revised to reflect the agreed to condition.

Despite appropriate specifications and communication, it was found that the high voltage batteries did not meet minimum coolant flow and back pressure requirements which resulted in insufficient cooling for the entire coolant loop. Through coolant flow testing, Kenworth determined that the battery packs were being cooled in series, restricting flow, and conflicting with coolant flow specifications. To rectify the issue, Kenworth required the supplier to redesign their cooling system to provide cooling in parallel, which resulted in an appropriately performing system but at the cost of a six-week delay. Kenworth first tested the cooling loop in parallel, using soft hoses which resulted in much improved flow, then had a steel manifold built to provide a permanent solution. Once the modifications were completed, testing of the new manifolds exceeded the minimum flow rate in liters per minute. All six battery packs were outfitted with these manifolds.

The battery modifications were required at early thermal simulation runs of the as designed cooling and chiller systems with parametric settings based on available bench test results suggested the vehicle cooling systems are adequate for nearly all predicted operating conditions. Subsequent predelivery tests validated these results.

The team had to research data loggers as the ones suggested by the analysis group and funding sources did not have enough security to prevent external unplanned access. This turned into a very difficult task and the initial loggers identified and installed were not performing to their specifications. This was found after completing data transfer speed tests on the mobile router installed on each truck, testing logger upload speeds from the chassis, and downloading information from a primary and secondary cloud



system. The transfer constraint was the upload speed from the logger to the router. The team met with the logger supplier and found that the logger specifications only covered its ability to capture data and transfer rates were not available to this group. With this knowledge the team researched logger options and identified data logging equipment that when tested met the data capture speeds, had security systems built into the hardware and encrypted the data during transfers.

Mechanical integration at the vehicle level was not without its own set of challenges. The e-motor and transmission companies wished to retain complete control of the shifting process regardless of the vehicle state and requested vehicle state conditions to optimize their shifting algorithms. This request could not be agreed to as the vehicle must have an option to sacrifice the sublevel components to protect higher level systems and occupants.

As the team progressed further into the integration, the team that the supplier's documentation stated that the onboard charger would work in both single-phase and three-phase modes, it had never been tested as a single-phase charger by the supplier. KW designed for single-phase charging, per specification, but because of the inaccurate documentation, was forced to return some of the chargers for rebuild.

During the integration phase, the prominent contributor to the vehicle delays was the DC-DC inverter. The product failed often and for multiple reasons. The supplier is a US supplier, but repairs and engineering are in Europe. This caused not only delays from failed parts but created return and repair cycles greater than a week and on at least one occasion, more than two months. The product system issues were never completely resolved, and the team had to take mitigating steps at the vehicle level to ensure the inverter would operate long enough to produce usable data.

The team defined the vehicle state conditions used to set the requirements for the system integration process and standards. The top-down approach is required to ensure final arbitration remain solely the responsibility of the vehicle manufacturer. This also limited and controlled the distribution of acquired information during field tests.

With the transition to system level controls, CAN bus noise issues were resolved by daily incremental improvements until a clean signal was achieved. The wakeup process was a near endless loop of finding and resolving errors on CAN.

It was found that electrical noise was being introduced on the CAN bus by most of the components, including the HV batteries. To mitigate the noise issues, opto-isolators were installed, along with band-pass filters. Additionally, it was found that the executive battery controller of the first generation of HV batteries caused too much noise to allow the system to function. The first generation of HV batteries were eventually replaced with second generation batteries to resolve this issue.

In passing the first threshold of commissioning readiness, the chassis had to meet the drayage operators three key performance characteristics, as identified in a survey of operators in 2013: 1) the vehicle must have sufficient power for operation (300 HP), 2) it must achieve the necessary range (150 miles), and 3) it must have the capability to be used on all delivery routes.

The Kenworth project team built this fleet of CNG hybrid Class 8 trucks to ultimately satisfy these requirements. The prototype vehicle drivetrain is capable of at least 480 hp, is tested to produce sufficient torque to pull up to a 6% grade and operate at freeway speeds when fully loaded. The engine and generator produce sufficient power to pull a GVWR of 80,000 lbs, unlike previous prototype Class 8 zero-



Project 17244: Final Report

emission trucks with systems sized to only transport a GVWR of 65,000 lbs. This latter feature gives operators added flexibility in deployment of trucks on multiple routes.

The testing challenge that the project was not prepared for was the closing of the only CNG station north of Seattle. This loss created a logistics nightmare for track testing. None of the stationary tank systems were available in this area as none of the NG suppliers wanted to deliver tank service away from the fill stations. The Kenworth team ended up towing the test vehicle from the test track to the nearest fueling station a short distance south of Seattle. This additional step required for refueling extended the test schedule by several months. After a period, this was no longer sustainable. Fortunately, most of the required track tests were completed and initial street level tests could begin nearer to the CNG filling stations.

As a final item, it must be stated that the selected 48V batteries received failed right at the start of the functional field tests. Once they failed to operate, the team broke the parts open and found examples of less-than-ideal assembly processes. The supplier was notified, and batteries were opened to determine the extent of the issue. Kenworth became an active member of the battery suppliers' assembly and test procedures. In parallel, the team also attempted to identify replacement product should the current supplier fail to build and test suitable replacements. However, the supplier completed the required repairs and provided sufficient documentation to ensure the product would survive the field demonstration.

SCAQMD set the delivery date for October 1st, 2019, and on September 26th, 2019, both chassis were loaded and shipped to TTSI.

Early tests while the vehicles were on-site at TTSI found that power steering controls on the second chassis were not operating as expected. The supplier provided a new controller and harness that were delivered to and by Kenworth R&D resources and installed. The system was tested and appeared to resolve the power steering issues. Although the vehicles were ready, the California DMV was not prepared to handle licensing procedures for CNG hybrid trucks. The trucks were, however, used to train drivers and first responders. During this lapse in field operations, the chassis were used for driver first responder training at the San Pedro fire station next to TTSI. Licenses were finally acquired, and the chassis were released for demonstration in early November

Initial operations of the vehicles started well. However, after a few weeks, the trained operator experienced a vehicle start up failure. The hybrid monitor indicated that the vehicle was stuck in the "Setup propulsion mode." Remote diagnostics indicated this condition was due to the HV batteries dropping below a minimum operating temperature. Root cause was an operator not enabling the battery heater during an overnight park.

The next significant issue was the complete failure of the 48V DC-DC converter on both chassis. The R&D Center team traveled to California as none of the acquired data was remotely accessible. The team found that the 48V DC-DC converter on HECT2.2 had an internal failure due to a temp sensor failure within the converter. The converter could not be repaired at the facility and was removed and prepped for shipment back to the supplier for diagnosis and repairs. HECT2.1 suffered minor a converter fault which was reset and able to return to service. Unfortunately, the drive motor was inoperable due to an internal failure which then allowed water and oil to mix. Therefore, the converter was pulled from HECT2.1, installed on





Project 17244: Final Report

HECT2.2 and one of the chassis was placed back into service. Arrangements were made to ship HECT2.1 back to Washington for a drive motor overhaul.

The R&D center pulled the drive motor and discovered two issues with the failed motor, the primary seal between the oil and water cooler had failed and allowed oil and coolant to mix and oil in the HV phase connection area of the motor. These repairs required the motor be returned to the supplier for root cause analysis and repairs. The root cause was determined by the supplier to be due to improper machining of a groove that holds a seal in place on the end cap and a failed seal around the connector cable.

During the motor repair period, the team pulled the motor drive converters purchased for HECT2.3 & HECT2.4 (the cancelled builds) and installed one of them in the HECT2.1. This converter failed very quickly and was returned with the other failed unit for repairs by the supplier. The team found from data that the converter faulted and failed when it approached the upper rated power conditions. The decision was made to cut power requests to a lower setting and install the final converter assembly.

The motor rebuild was completed and with the lower converter power demands set, the chassis produced solid performance and reliability characteristics. With commissioning and functional tests completed, the team needed to stress the system and collect performance information against a baseline truck. The timing was opportunistic in that the original HECT chassis was returned to the R&D Center after completing its demonstration period.

HECT and HECT2.1 were prepped for a fuel economy run. Several short runs around the Seattle area were completed to test data collection capabilities and ensure collected data was comparable when under analysis. The drive that appeared to generate the most stress on their systems was a sustained run between Seattle and Portland. This run is a long rolling hill route with little opportunity for regenerative battery charging. The test was practiced a couple of times, both test chassis and a support team were deployed to capture information and keep the chassis running. The date selected for analysis had the correct wind speed, low humidity, and clear skies. The run was completed, and the data was uploaded for comparison analysis. The results were submitted in the vehicle comparison report and showed a significant improvement in fuel economy.

In summary, the chassis successfully completed local reliability testing. A combination of local routes, multiple drivers and varying loads were employed to test the limits of the latest repairs and updates. When the designated routes were completed, the chassis repeated the local tests, fuel economy runs and reliably operated for a full week of fault free operation with and without loads and returned to service in Southern California.

Issues from this point forward were primarily related to power steering failures and faults, with occasional issues related to the HVPD and the hybrid ECU. Iterative software improvements were completed in response to issues as they arose, including CAN noise reduction improvements, sequencing pump on conditions with ignition, cooling fans at startup, updated inputs for trailer and service brake settings, gear selection display on dash, air compressor controls, and various generator and engine torque tuning.

Then the Corona-19 virus hits. The nation and industry operations around the country shut down. Included in this shutdown were the chassis located and operated by TTSI at their Carson CA facility and parked for the duration of the California port authority shutdown. TTSI operations slowly returned over the next five months with drivers and freight returning to move containers as directed. With the increased





freight volumes, the demonstration vehicles were returned to service when it made economic sense to TTSI.

During the virus induced shutdown and quarantine period, Kenworth relocated an engineer to California as travel restrictions prevented engineers from resolving issues within reasonable time frames. The engineer performed work directly on the vehicle, managed and supported supplier visits and coordinated local dealer repairs. Fortunately, the Covid shutdown occurred towards the end of the demonstration period and at a point where the chassis started to experience wear and fatigue type operational faults. These were the type of failures expected for this project. These issues were from the LV connectors and harnesses vibrating loose or wearing through, main engine overlay harness faults and power steering faults.

Examples of ongoing issues include but is not limited to a high voltage coolant pump fault that shut down the main motor drives switches. In other words, our self-protect mechanism in the software preformed correctly, de-rated the drive motors for a high temperature reading and managed a controlled shutdown of the vehicle. The team traced the fault and repeats to a single pump. The harnesses and connectors inspection and test found no issues. The pump test indicated a pump failure, the pump was removed, and a spare was installed. The controls team updated the chassis software and firmware multiple times for the transmission, auxiliary components, shore power charging system and the high voltage distribution switches.

For the critical fault, a review of the captured data indicated that the HV batteries stopped broadcasting their operational signals and the main drive controllers were properly shutting down. Although the test verified that the software systems were responding correctly, the team required supplier support to determine why the batteries stopped sending their signals, find a solution and upload the software modification. Local tests again suggested the issues were resolved and the chassis was returned to service.

Last point of discussion is the power steering assembly (Figure 1). Both demonstration chassis suffered repeated albeit multiple different types of failures to the power steering pump, converter, and controls systems. The final issue and the root cause were a dual failure of the electric motor and resolver. This



Figure 1: Prototype Electro-Hydraulic Power Steering System



Project 17244: Final Report

turned out to be a very difficult failure to resolve. The inconvenient aspect of this failure was due to the uniqueness of this assembly. This version of the power steering system became obsolete shortly into the project. The supplier used the failure information to improve and redesign their product. Therefore, we had to make this system work. The assembly was inspected by the dealership, on site engineer and the supplier but no issues were found.

The next step was to tear the system apart and inspect for issues. The system was inspected for wear to the wiring assembly around the resolver and cover plate, but no issues were identified or found. While the steering control was exposed, the chassis was started, and the motor was found to be operational, but the power steering was not working. The chassis was shut off and the motor was reassembled and

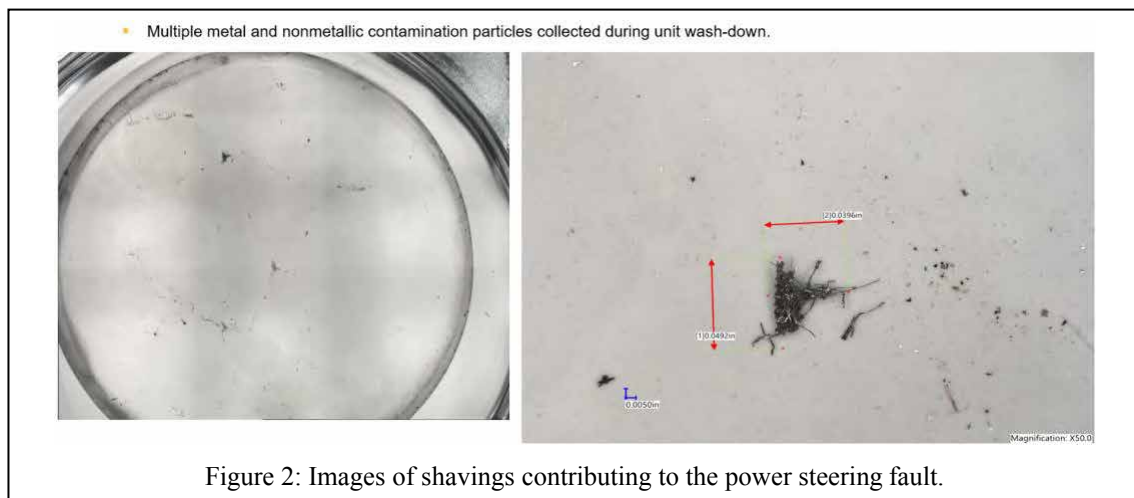

removed from the chassis. The failed power steering unit was returned to the supplier for disassembly and inspection. The observational information was supplied to the power steering supplier as this suggested that the motor resolver was not the issue behind the faults. The power steering supplier agreed with this assessment and scheduled a technician to replace the pump and valve system. The subsequent supplier inspection of the original assembly found metal shavings and debris in the pump and valve. These shavings were large enough to cause the valve to stick in position and fault out the power steering system (Figure 2).

The other chassis operated without issue until the last week of September when its power steering system stopped working but did not generate a fault signal. The chassis was parked at the Kenworth Carson dealership. The Kenworth team reviewed the operational data and believed that metal shavings were the root cause for this failure. The information was shared with the power steering supplier, and they are building a replacement motor and valve assembly that will be installed in the chassis as quickly as possible.



Project 17244: Final Report

Unfortunately, the vehicle registrations expired before the repairs could be completed and validated (Figure 3). This was not a desirable end to the demonstration period where both chassis were inoperable due to power steering faults. The chassis were eventually loaded and shipped back to the Kenworth R&D Center for a final inspection and repairs.



Figure 3: Chassis at TTSI Terminal Island Facility



Phase 2: Stop Work Issued

The SCAQMD stop work order was received August 5th, 2019.

Although the work on phase 2 vehicles had stopped, the phase 2 vehicle design improvements were started shortly after project execution, and within a year all components had been identified and initial orders placed. Lead times for some of these components have stretched longer than suppliers initially stated, and our plan to have the first truck substantially complete by the end of 2018 became unachievable.

Although the Phase 1 vehicle integration issues were resolved. Albeit too late too late in the project timeline, many of the components for the second phase were delivered after the stop work order had been issued. This event turned into a fortunate condition as many of the parts ordered were required to keep the first two truck operational. The project ended up using up nearly all the parts ordered to keep half the original build in operation.

In retrospect, the cancelling of the second phase of the project wasn't necessary as the project continued to run for an additional one and half years. SCAQMD requested the demonstration period be extended until December 2021 and Kenworth agreed to support this request.

Field Demonstration Discussion

Commercial vehicles require significant design improvements over the automotive and transit industry. This was found to be true for most of the parts used on this project. It should be noted that there are exceptions and those companies that survived this demonstration are better prepared to enter production volumes with a certain degree of confidence.

Kenworth entered this project with the need for field failures on the vehicle and reported this request to the operators, TTSI, funding sources and analysis groups. Not that Kenworth wanted the vehicles abused, but we needed to learn where our design estimates were wrong. Learning lessons from this project is an incredible opportunity to learn how to better design and build a product. The toughest lesson learned from this project was the expectation that prototypes are expected to perform like and be as reliable as production units.

The two prototype vehicles were demonstrated over the two-plus-year deployment period on multiple routes and duty cycles. This variation in service suggests that although operating hours for the test vehicles were less than ideal, the product can be expected to adequately serve near-dock, local, and near-regional destinations. With effort, the vehicles were able to achieve full range capabilities to serve all regional destinations in the future and is anticipated because of further reductions in the size and weight of battery systems, efficiency improvements from component integration, and added capacity to onboard storage tanks will be very competitive products against a standard diesel vehicle.

An example of an issue that contributed to the slow accumulation of commercial service miles, was the repeated failures of the HV-LV DC-DC inverter. The inverter was designed and built to meet design requirements but continued to fail at full design load. As there were no other options for this part, and fortunately the team bought units for all units from the original fleet number. These extra units were installed on the built units and failed units were returned for repair and testing. Unfortunately, the parts continued to fail at rates faster than the repairs. These failures forced a return of the deployed vehicles





Project 17244: Final Report

to the Kenworth facility for rework. The lesson learned from this activity is know where the parts are design, built and assembled and make sure they have the full range of support in North America. We learned that although the supplier is based here in the states, the hardware was assembled in Eastern Europe and the software was developed in Asia. As these parts were not in production, local engineering and technical support was not available and the supplier hadn't created any type of support plan for the project. Parts had to be air shipped across an ocean and experts had to travel overseas to provide local support. None of the repair or investigative activities were quick or simple. However, the supplier did provide the necessary support and for that, Kenworth is grateful.

Operator acceptance is a key element for these products. Their mode of operation is income based and vehicle performance and reliability remain key characteristics of a commercial vehicle. Although these tractors do not meet Kenworth's production quality standards, the operators commented that they preferred driving these vehicles as they were more reliable than competitive prototypes, were quieter and had better short distance control.

Covid-19 nearly ended the demonstration and forced alternative solutions not considered or planned for in the project estimates. Vehicle downtime for any reason is still an opportunity to effect repairs, complete updates and provide software updates in preparation for a return to service. Quarantine, travel, and isolation restrictions limited all activity within the company and prevented any of the local experts' access to the parked vehicles. A volunteer engineering resource has relocated to California to support KW hybrid field operations during the state mandated isolation periods. The issue was training and preparing this resource on the vehicle systems and operations before moving the engineering to the Los Angeles area. Granted the engineer couldn't resolve all the issues, they were able to act as a conduit for information and vehicle access to the local experts and allowed them to investigate issues and try ideas until solutions could be found and implemented.

As has been expressed, the HECT2.1 and HECT2.2 operated by TTSI experienced multiple issues. However, some of these issues were not from the chassis. Both chassis have experienced cold battery issues. Winters in Southern California are cool enough to derate the charge ability of HV battery packs. This means that, although there is an engine on the vehicle, the chassis still must be plugged in to keep the batteries warm.

A side-effect of the cold HV batteries is the depletion of the low voltage batteries. Several instances were found where either a coolant pump did not operate correctly either because the operator forgot to plug the vehicle into grid energy, or the outlet GFCI had tripped, and no power was available, or the operator shut all HV and LV power off and the vehicles couldn't accept grid power. With any of these faults, it quickly became apparent that the low voltage disconnects became an extremely critical aspect of parked vehicles integrity. And the location to reset the disconnect must easily accessed and must trip at a higher level to ensure the vehicle can reset and start after an extended park period. All valuable lessons that will be incorporated into future vehicle state controls.

To close on a positive note, the public CNG filling stations worked without issue on these vehicles (Figure 4). The processes TTSI had in place for their CNG fleet were quickly and efficiently adapted for use during this demonstration period. Fueling standardization certainly made vehicle refueling a non-issue and allowed the company and drivers to focus on vehicle operations, providing feedback to the remote teams and relieved the local resources of one less issue to keep vehicles in operation.





Figure 4: Demo Chassis at Public Filling Station

Support Activities: Beyond the Vehicle

Data acquisition was more difficult than originally considered. The amount, integrity and protection of the data required a system not built for mobile applications. The need for real time analysis during the field tests was incredibly difficult to achieve. There are no systems capable of delivering this information securely to remote groups. Many hours of testing equipment and systems were required before the system and components we have and use today were reliable enough to produce the necessary data.

Secondary to acquiring the data, was the parsing of the data into usable streams, setting up secure transfer sites and comparing the test data to ensure it was transmitted and received without issue.

It was decided early to use the secure box site from Ricardo to transfer and hold the vehicle data logs from September 2019 to present. It should be noted that only commercial service data starts in October 2020, data prior to this is test data and data from the period when the chassis were returned for repairs in Washington state are not.

Operator and First Responder training was well received, and all parties were grateful for the vehicle introduction and reference material shared and kept on the vehicle. First responders were very grateful for the e-stop button on the dash and the fact that all vehicle power was neutralized within two seconds of hitting that switch. It should be noted that the HV neutralization is within two seconds of the key off switch, but the shutdown is controlled, and the vehicle wake up procedure is automated. The e-stop process requires engineering involvement to reset and wake up the vehicle for continued operation.

Besides the Covid shut down, TTSI shut the vehicles down for a planned operation move from terminal island to the city of Carson. The fleet was split and were housed at both locations after May 2021.



Comments and Conclusions

To describe the start of the project, we must look at the Zero Emission Cargo Transport (HECT) demonstration (DE-FOA-0001106) that led to this project. The introduction of this project is a lesson learned by stating the mistake of linking successive projects progress to the successful release of the previous chassis for field demonstration (Figure 5). Another lesson learned was our lack of understanding on how quickly the regulatory environment would transgress from near zero opportunities to only zero emission technology and the public acceptance to this transition. Although the earlier project covered both zero and near zero emission technology, Kenworth missed the signs that Fuel Cell development would progress to the point where it could conceivably compete as a primary power source for heavy duty vehicles. This was a tough lesson to learn, and although granted opportunities to deviate from our project commitment schedule, Kenworth failed to successfully deploy the full fleet without ramifications. This fact is accepted, and all efforts were implemented to move the project forward to completion.

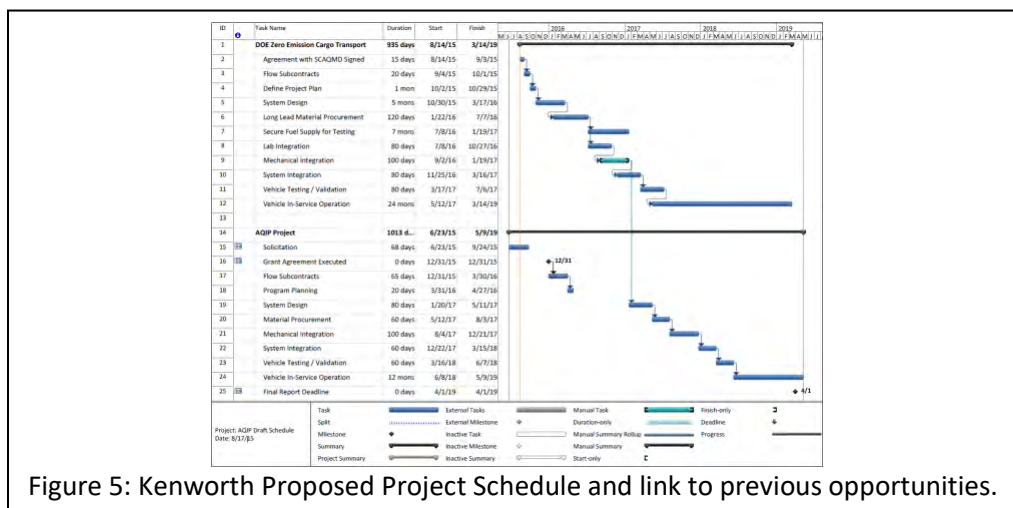

Figure 5: Kenworth Proposed Project Schedule and link to previous opportunities.

The chassis are unique in nature and within Kenworth there are only three of these units. It was decided to use the original CNG hybrid as the baseline unit and offer comparison between them (Figure 6). All KW CNG hybrids use the Cummins L9N engine coupled to a 250kW generator. No engine modifications were required for this application, and all were factory installed.



Figure 6: Stock Cummins L9N Engine



Project 17244: Final Report

The L9N engine is certified to the California Air Resources Board (CARB) optional low NOx standard of 0.02 g/bhp-hr – a 90 percent reduction from engines operating at the current Environmental Protection Agency (EPA) NOx limit of 0.2 g/bhp-hr. In addition to ultra-low emissions, the L9N features on-board diagnostic capability, a maintenance-free three-way catalyst, closed crankcase ventilation system, and an engine control module with excellent durability. The L9N has demonstrated the ability to lower NOx emissions by 80 percent below that of the Euro VI standard of 0.46 grams per kilowatt hour (g/kWh). PM emissions reduction is equally impressive with levels over 90 percent lower than the 0.01 g/kWh standard.¹

The final challenge, prior to the Covid-19 outbreak, was the lack of experienced vehicle electrification resources at all levels and the lack of available training to produce functioning resources. The heavy-duty vehicle market is a stolid conservative group used to developing products with long operational life based on successful experiences. Introducing electrified systems, components and vehicles to this group was less than well received and required time for key players to ramp up interest and support this transition.

In 2016, at the start of this project, there was still a consideration for a bridge technology and Kenworth proceeded on the assumption that the initial project vehicle would be released for demonstration within the second year of this project. Kenworth couldn't have been more wrong in this assessment. At the time of the project start, electric component and startup suppliers did not have a solid understanding of the commercial vehicle industry, heavy truck suppliers didn't have a strong understanding on how to electrify their components, and customers demanded systems that were as reliable as the products that are in use today. This demand triangle was not an attainable scenario, and products were struggling to meet quality and reliability targets that make commercial sense for the end users. Unlike automotive electrified products, which initially are luxury purchases, commercial vehicles are capital purchases and must operate to meet customer business needs.

At the vehicle level, Kenworth did modify the power management strategy to better use a greater amount of stored energy in the HV batteries than was done on the original chassis. This equates to a significant reduction in engine run time during normal vehicle operations and further improved fuel economy. In other words, the engine was run less often, was off for longer periods and engines don't consume fuel when they are not running.

¹ Cummins Inc., <https://www.cummins.com/engines/I9n-2018>





Project 17244: Final Report

The chassis in this test used the same main engine and generator as the previous CNG hybrid and is used in the same application. Chassis specifications are noted here for direct comparison. The route driven is approximately 360 miles round trip along Interstate 5 between Seattle and Portland (Figure 7). The demonstration and baseline chassis were loaded with the same trailer weight, driven at the same time on the same day with the same operators. The results suggest that the demonstration hybrid vehicle in a regional haul application will consume significantly less fuel than the original prototype hybrid. The baseline vehicle was shown to have better fuel economy than a standard vehicle and that report is published in the previous project.

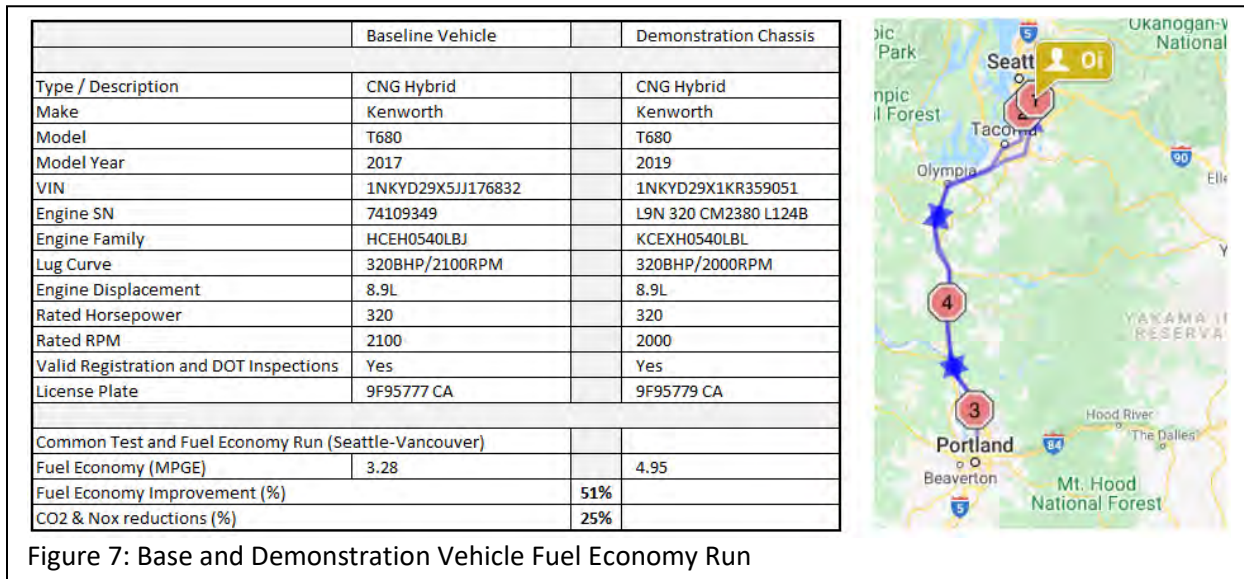

Figure 7: Base and Demonstration Vehicle Fuel Economy Run

Besides the improved fuel economy, there are some very important lessons to learn from this project:

- Tier one suppliers are preparing for the transition from fossil fuel to electric powered vehicles. It is not yet understood how the rest of the supply chain is preparing or what their state of preparedness is.
- OEM's and Suppliers are hesitant to make production investments. The market for hybrid commercial vehicles is not large enough to cover the cost of investment. And technical improvements on a year of year cycle may make some of these investments obsolete before costs can be recovered.
- Mergers and acquisitions are slowing down product development cycles. The final companies must spend time absorbing or integrating with each other and this effort takes resources and funding away from product development.
- OEM's and hybrid powertrain system developers are at odds over ownership of the power management strategies. The efficiency of the vehicle and the performance of the vehicle is unique to each company and this information must remain with the vehicle manufacturer to set them apart from their competitors.



Performance

The HECT 2 truck design will provide the following performance metrics

Parameter	Expected Performance
Max battery charge	~100 kwh
Max torque	2000 Nm total (1475 ft-lb)
Range	150 miles
Top Speed	62 mph
Grade ability	6.5% Grade at 20 mph 5.0% grade at 30 mph
EV mode (electric only) Range	30-40 miles or 1 hour of operation depending on duty cycle and trailer load
Operating temperatures	16F (-9C) to 135F (57C)

*Note: All performance parameters tested with a vehicle GVW of 65,000 lbs.

Chassis Specifications

Item	Specification	Comments
GVWR	>33,000 lbs.	GVWR for Class 8 trucks
GCWR	80,000 lbs. max	61,000 lbs average
Engine type/Rating	Stock Cummins L9N engine / 320 hp	Un-modified production engine
Engine fuel	CNG	
Fuel tank capacity	150–200 US DGE	Agility Fuel Tank Assembly
Hybrid motor rating	300 kW	Fully integrated electric motor-transmission and inverter assembly
Transmission Type	Automated Manual	
Power assist Steering	Electric over hydraulic	Custom
Tire specs	Smart Way Certified	
Acceleration	Equal to or better than conventional vehicle	
Interior noise	Per FMCSA Part 393.94	
Exterior noise	Must comply with federal, state & local noise ordinances (FMCSA Part 325.7)	
Fuel economy	20% or greater	

Source Credit: Kenworth Truck Company



Appendix:

Intro to Electrical Components

Several electronic components are powered by the 650V batteries. The HV batteries connect to the high voltage power distribution unit (HVPD). The HVPD then provides power to both accessory motor controllers, and DC to DC converters to supply either 12V or 48V as needed by the component. The 48V DC to DC converter charges the 48V battery, which is used for pumps and fans. The 12V DC to DC converter charges the 12V battery, which is used for standard truck accessories (Figure 8).

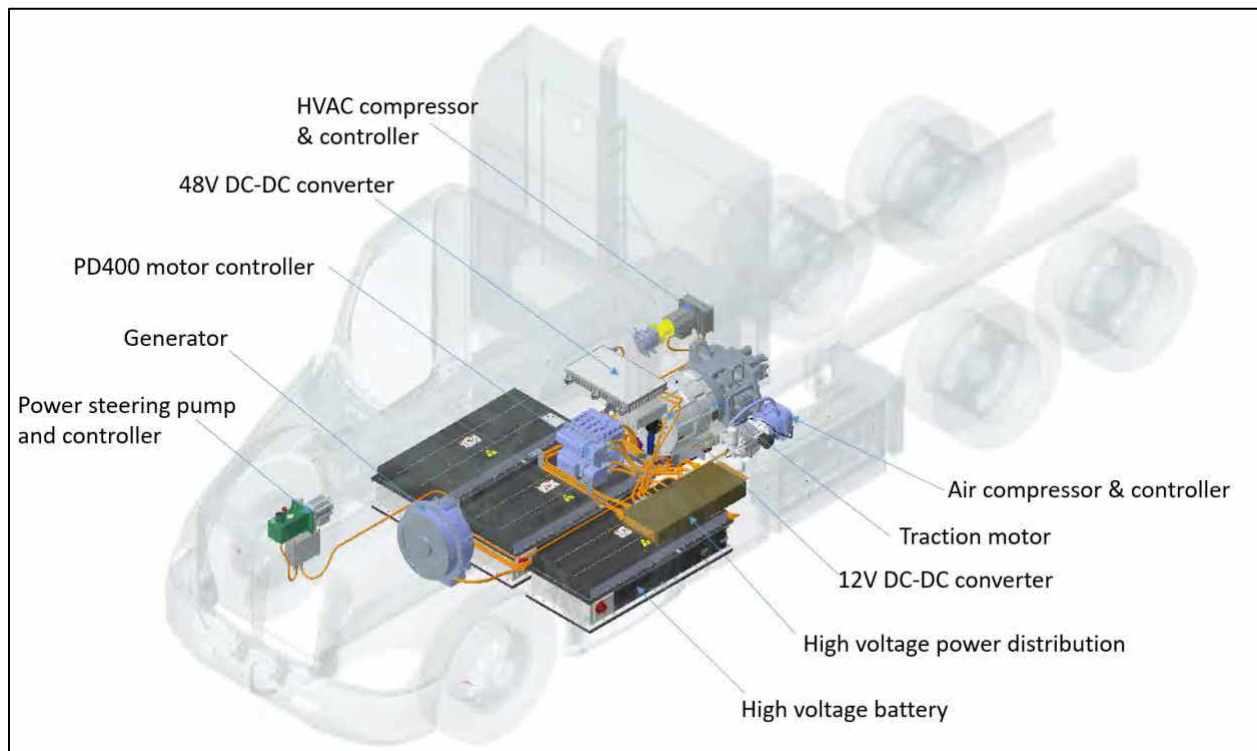

Figure 8. Hybrid Specific Electronics

Intro to Propulsion System

The HECT truck is not driven by the compressed natural gas (CNG) engine. Propulsion for HECT is powered entirely by a 650V Three-phase AC traction motor (ACTM) driven by three large 650V batteries (see Figure 9: Propulsion system). The DC output from the batteries is converted to three-phase AC by the PD400 motor controller, which in turn drives the motor. The ACTM consists of two motors mounted in series (Figure 9).

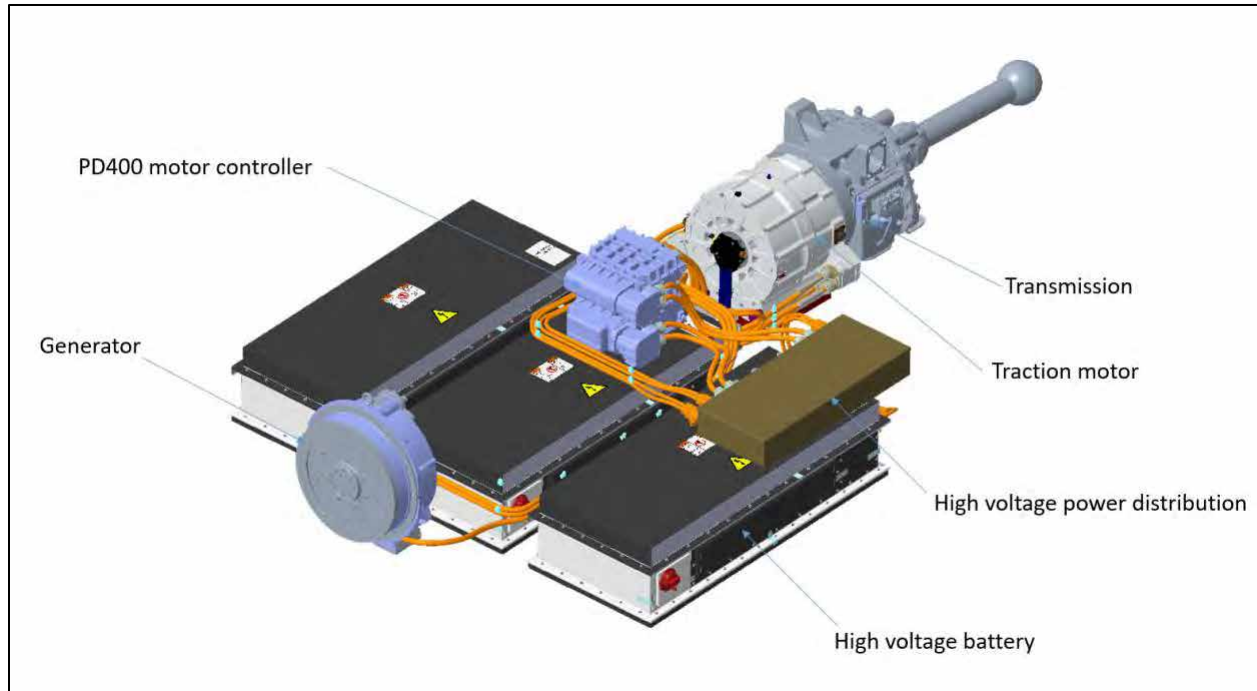

Figure 9: Propulsion system

Intro to State of Charge & Fuel

The state of charge (SOC) is a measure of how much electricity is stored in the batteries and is shown on the B-panel display. The fuel gauge in the instrument cluster only shows compressed natural gas, it does not show battery SOC. While in operation, the CNG engine is used to turn the generator to recharge the batteries. When the truck is in EV mode, it will prioritize using battery power over generated power. When the truck is in hybrid mode, the CNG engine will automatically start to maintain an acceptable SOC.



Custom changes to the T680 Cab

Emergency-Stop Button (E-Stop)

Located to the right side of the B-Panel, the Emergency Stop button (Figure 11) will disable high voltage electrical power when pushed. This will disable all traction power and all powered accessories, including power steering. This button is intended as a last option in case of a run-away or unresponsive truck and should not be used under normal conditions. Pressing the button may result in damage to the truck systems.



Figure 11: Emergency Stop Button.



B-Panel Display

The B-Panel display is an interactive touch screen that provides systems information for the operator (Figure 12).

In the display is a status message at the top, and three circular indicators below it. From left to right, the indicators show; state of charge (SOC), CNG engine metrics, and motor metrics. The engine indicator includes engine speed, temperature, and output power. The motor indicator shows temperatures for both motors and output horsepower.

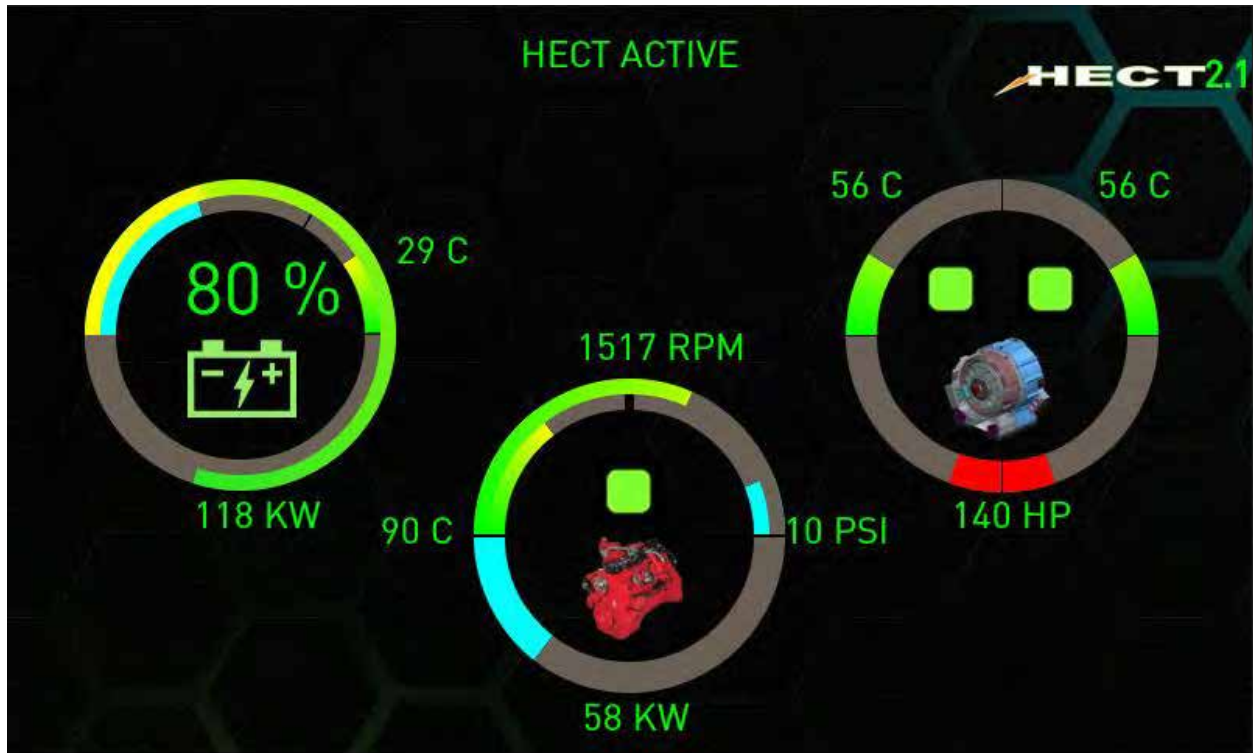

Figure 12: B-Panel Display





Project 17244: Final Report

Low Voltage Battery Disconnect Switch

The low voltage battery disconnects (Figure 13) switch controls activation of the 12V and 48V batteries and is the main battery disconnect for the truck. Turning this switch off is the equivalent of disconnecting the battery. This switch has a sliding back panel that will cover the opposite function. When the truck is in the “on” state (Figure 14), the slide needs to be slid in the down position to reveal the “off” position (Figure 15). The low voltage disconnect should be switched off when the truck is unattended for extended periods.

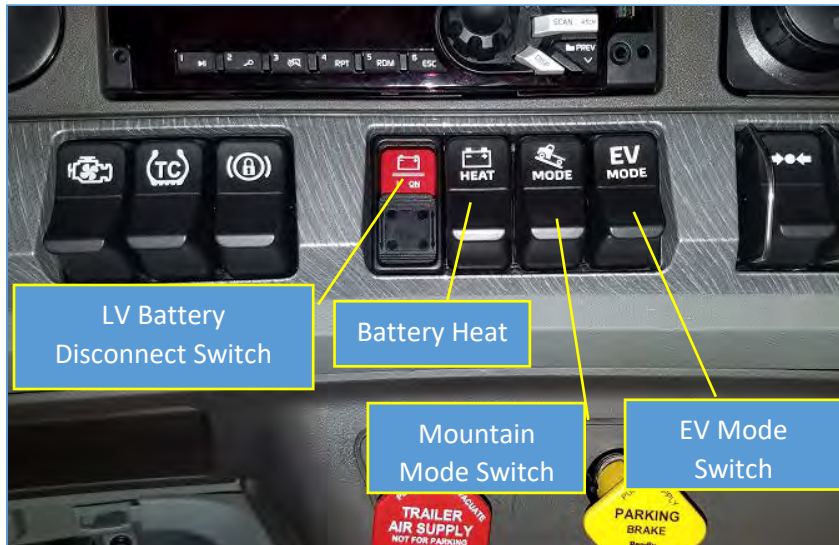

Figure 13: LV Disconnect, Mountain Mode and EV Mode switches



Figure 14: Slide the switch cover



Figure 15: Off position



Project 17244: Final Report

Mountain Mode Switch and EV Mode Switch

There are three modes selectable with HECT: EV mode, hybrid mode, and mountain mode. With both the mountain mode and EV mode switches shut off (Figure 6), the truck will be in hybrid mode. Each mode controls the trigger and rate at which the generator charges the batteries. In EV mode, the generator will only engage if the SOC is below 19%, then will stop again once 25% SOC is reached, and is intended for minimal engine usage. In hybrid mode, the generator will engage when SOC is below 50% and will disengage when SOC is greater than 60%. Mountain mode is intended to be used when climbing long grades and will engage the generator when SOC is below 80% and disengage when SOC is above 85%.

Data Logger

Located inside the cab, between the seats, is a data logger (Figure 16). There are no serviceable parts. All equipment reports wirelessly to Kenworth. The data logger captures both GPS location information and CAN traffic data.



Figure 16: Data logger



Project 17244: Final Report

Right Hand Stalk

Operation of the right-hand stalk is the same as with a standard T680 cab. However, instead of activating different levels of a retarder, the stalk activates regenerative braking at three different levels: 33%, 66%, 100% of engine torque respectively.

The HVPD (High Voltage Power Distribution) Unit

ONLY TO BE PERFORMED BY A CERTIFIED TECHNICIAN WITH HIGH VOLTAGE TRAINING. ONLY WITH CERTIFIED HIGH VOLTAGE EQUIPMENT.

- Cone off entire vehicle.
- Disconnect the LV batteries by sliding the Battery Disconnect switch cover and pressing the off button on the Battery Disconnect switch located on the dashboard.
- Disconnect the HV batteries by turning the HV battery switches to the off position for all HV batteries.
- The switch can be locked out with a tie wrap that will prevent the switch from being energized until removed.
- Once used, the battery disconnect switches will disconnect the HV circuits from the other truck systems. Important Note! The battery disconnect switches will not disable the HV circuitry within the ESS.
- **Wait five minutes** and then open the HVPD (Figure 17)

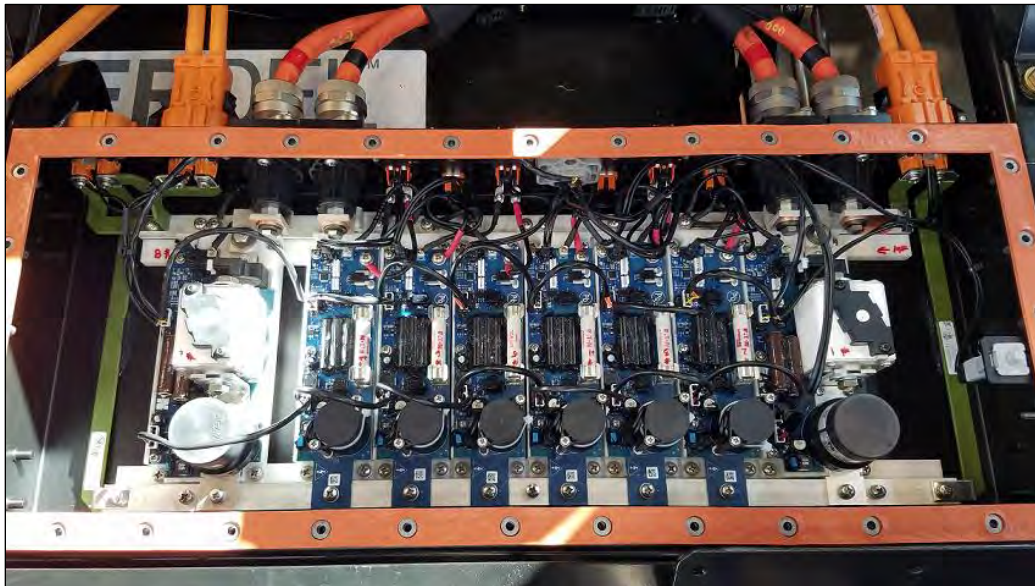

Figure 17: High Voltage Power Distribution (HVPD)

- Verify that HV is not present within the HVPD by using the Fluke 1577 meter across the internal bus bars.
- Verify if fuse is opened or closed.
- Replace fuse if open.
- Close HVPD before re-connecting the LV batteries and switching HV batteries on.



External Low Voltage Power Distribution Switch

LV power can be enabled or disabled from the disconnect switch inside the cab. However, if LV needs to be enabled or disabled outside the cab, it can be done directly on the low voltage power distribution box (LVPD), as indicated in the figures below (Figure 18 & 19). The LVPD box is located on the passenger side, behind the side panel. Toggle the switch toward the front of the truck to switch the unit on. Toggle the switch toward the back of the truck to switch it off.



Figure 18: Inside the low voltage power distribution box. Switch circled.



Figure 19: The LVPD box is located behind the side panel





Safety

HV Introduction and Training

We identify any electrical system that is over 60V as being “High Voltage”. At 50V and above we are operating with electrical systems that can be fatal if contacted.

Never cut any orange cable or cut into any box identified as part of the HV system.

There is a safety interlock system that will disable the HV system whenever a HV cable is disconnected.

Normally, you should not need to work on the HV areas of the truck. If you are going to be working on the HV areas of the truck you should take the following precautions:

- Get trained and authorized (Follow company policy)
- At least one additional staff member must be present when you are working.
- Get an electrical rescue hook
- Use only the Fluke 1577 meter when making measurements.
- Only use tools that you have been trained to use.
- Use only insulated tools on HV components.
- Keep the area clean and put away tools.
- Wear non melting/flammable clothing.
- Remove rings, watches, and other conductive items.
- Review work completed since last time you were there.
- Plan work you are going to complete.
- Have a qualified work partner, who observes with a rescue hook.
- Use one hand, if possible, keep other hand off chassis.
- Leave the area when not working.
- HV Gloves

Working on High Voltage areas of the truck

- The only HV area to be accessed is to replace fuses in the HVPD.
- Contact Kenworth R&D before working on any other HV area.
- Under no circumstances should anyone attempt to open or service any hardware contained in the ESS.





Fault Matrix

Fault #	Fault Event	Solution 1: Operator	Solution 2: Dealer	Solution 3: Dealer + OEM	Common Cause
	HVIL Fault	Reset E-Stop. Power Cycle Procedure.	Check HVIL circuit	Contact KW	
	Power Steering Low Oil Level	Contact Dealer	Fill with appropriate fluid	Contact KW	
	Power Steering Oil Level Critical	Contact Dealer	Fill with appropriate fluid	Contact KW	
1	“Wait to start” on B Panel persists on ignition	Power Cycle Procedure	Check LVPD fuses, Check LV voltage	Consult diagnostics and contact KW	
2	“Wait to start” on B Panel persists on crank	Power Cycle Procedure	Check LVPD and HVPD fuses	Consult diagnostics and contact KW	HVPD contactor not closed, LV relays not closed
3	Stop Engine Warning on instrument cluster	Power Cycle Procedure			System Fault
4	“Engine Stopped” message and no “Stop Engine” warning on instrument panel	Power Cycle Procedure	Check HVIL on Raptor	Contact KW	HVIL chassis splice failed, HVIL input fault
5	“Engine Stopped” message and “Stop Engine” warning on instrument panel	Reset Emergency-Stop Button & Power Cycle Procedure	Check Emergency-Stop Fuse/switch/firewall connector and troubleshoot harness	Contact KW	No power on HVIL, Harness failure
6	Won't complete up/down shift	Power Cycle Procedure	Check transmission DTC.	Contact Eaton	No comm on Raptor, Transmission position sensor failure, Speed sensor failure
7	MIL/Check Engine Lamp	Power Cycle Procedure	Check DTCs	Contact KW	System Fault
8	Won't go / nothing happen	Check disconnects switches	Check LV battery voltages / charge	Contact KW	Disconnect switches off, Dead batteries



Deliverables Summary Report

- Task 4.1.1 Deliverable: vehicle design documentation of completion
See document: [ScheduleMemoRev2.pdf](#)
- Task 4.1.2 Deliverable: models and drawings, order for parts
See document: [BoM HECT2.0 Assy Status.pdf](#)
See document: [2018-09-21 GGRF_Layout.pdf](#)
- Task 4.1.3 Deliverable: order for chassis
See document: [CHASSIS_ORDER.pdf](#)
See document: [CHASSIS_CODES.pdf](#)
- Task 4.1.4 Deliverable: HEV assembly documentation of completion
See document: [BoM HECT2.0 Assy Status.pdf](#)
- Task 4.1.5 Deliverable: HEV mode report
See document: [2021 AQMD Chassis Ops Report.pdf](#)
- Task 4.1.6 Deliverable: vehicle design report, vehicle acceptance by TTSI
See document: [HECT2_Chassis_Design.pdf](#)
- Task 4.2.1 Deliverable: baseline vehicle emissions testing results/report
See document: [Kenworth Hybrid Comparison.xlsx](#)
- Task 4.2.2 Deliverable: demonstration vehicle emissions testing results/report
See document: [Kenworth Hybrid Comparison.xlsx](#)
- Task 4.2.3 Deliverable: installation of CARB approved data loggers on demonstration vehicles at TTSI
See document: [2019-06-14_KW_ARB_Dataloggers.pdf](#)
- Task 4.3.1 Deliverable: confirmation of delivery of demonstration vehicles at TTSI
See document: [Confirmation of Delivery of Demonstration Vehicles at TTSI.pdf](#)
See document: [2019-10-01_AQMDAcknowledgementOfPhase1.pdf](#)
- Task 4.3.2 Deliverable: documentation of maintenance/repairs of demonstration vehicles at TTSI
See document: [HECT2.0 Service Manual.pdf](#)
See document: [Quick Reference Guide.pdf](#)
- Task 4.4.1 Deliverable: operation and training manuals for demonstration vehicles
See document: [Operators 1 Pager – HECT 2 V03.pub](#)
See document: [Operators Manual – HECT 2.pub](#)
See document: [HECT2 Service Manual V0-12.docx](#)
- Task 4.5.1 Lessons Learned
See document: [GGRF_AQIP-Lessons Learned](#)
- Task 4.7.2 CNG Fuel Station
See document: [TTSI Memo](#)
- Task 4.8.2 Data Collection
See document: [GGRF_AQIP-Performance Matrix](#)



Task 4.11 CARB funding for project management has been removed, can only be invoiced to South Coast AQMD

See document: Reimbursement 001 requests assign project management costs as requested.

Project Task Status

CNG Range Extender		
Task #	Description	Status
	Program Management	✓
	Vehicle/System Design	✓
	Long Lead Procurement	✓
	Lab Integration	✓
	Vehicle Mechanical Integration	✓
	Vehicle Electrical Integration	✓
	Testing/Validation	✓
	Commercial Operation	✓
	Data Collection & Evaluation	✓
	Commercialization Roadmap	✓





Attachment 1: Marketing Report

The technology and vehicles were well received by the customer and fleet manager. The drivers' feedback was very good even with the number of technical difficulties. The CNG hybrid vehicle's ability to compete with standard diesel vehicles in performance and weight are key characteristics for customer adoption. The other key characteristics, cost and reliability require attention. Any technology that is introduced to the commercial vehicle market must compete in all four categories: performance, weight, cost, and reliability. Any deviation from the diesel standard will have a negative impact on market penetration and customer adoption.

The demonstration project is also an opportunity to begin developing a local resource pool. Meetings with local education resources, dealer technicians and customer responses were used to generate a list of opportunities for local public and private academic institutions.

The project presented evidence that CNG hybrids can compete with diesels, offer a reduction in greenhouse gas emissions and with time will be cost competitive. It also should be noted that the technology received routine maintenance locally thereby providing job opportunity growth around the deployment areas.

When hybrid vehicles compete from a cost, weight and performance measure, the market will be completely disrupted. Any deviation from the above will deter the acceptance of commercial electric vehicle products. Today's technical limits suggest that Class 8 heavy duty zero-emission trucks are found to perform best when operating in the Short Haul/ Regional Haul truck category. In this commercial category, two specific applications that are most likely to first adopt near zero-emission technology pick-up-and-delivery and regional haul.

However, regulations are such that fossil fuel hybrids do not meet zero emission standards. Therefore, Kenworth has elected to pursue development of battery electric and fuel cell electric Class 5-8 vehicles for all applications. Many of the components tested in this demonstration project will be carried forward albeit modified to resolve issues noted in the lessons learned. Kenworth has Class 7 & 8 vehicle ready for production and sale at the close of this project and projects to have fuel cell electrics ready for production before 2030.

Attachment 2: Labor Report

The project leveraged local dealerships and trained technicians to support standard vehicle repairs and maintenance. Hybrid related repairs were limited to R&D and supplier engineers and specially trained technicians. Unfortunately, most of the vehicle issues experienced during the demonstration period required Kenworth R&D engineering support. This project clearly demonstrated that product reliability and local well-prepared support is vital to the success of electrified vehicles.

At the project start, local technical support was non-existent and training for local support was directed predominantly toward the automotive market. The lack of available local training programs to support commercial EV/HEV deployment as growth industry made it difficult to resolve field failures quickly and efficiently. The demonstration also suggested that skilled resources must be tightly regulated to the availability of jobs related to commercial electric vehicles and the infrastructure products needed to keep these vehicles powered.

Should resources, vehicles and infrastructure growth and development plans do not align, this has the potential to limit economic opportunities to resources, facilities, and products.



Attachment 3: Lessons Learned Report

One of the significant lessons learned from this project is the commercial vehicle supply chain is not yet completely ready to produce and support mobile products in the field at volume. There are many who are ready, but not all. A significant effort will be required by the OEM's, customers, dealers, and service providers to keep these vehicles operational. This is not a fault for trying. This is an inertial limitation. The volume of vehicles and the number of systems that must transition from existing products to electric products will take time.

There were many other lessons learned from this project. Kenworth learned that it takes time and experience to develop a product that is more technical and complex than a diesel vehicle. The technical are not unreasonable and the complexity will reduce with time and experience. However, the challenge is still ahead as the product moves from R&D to production.

Many of the challenges faced in this demonstration will have incoming inspection requirements, durability, and reliability tests to improve down time and stable production process to improve integration and service conditions. In other words, the faults are now known, will be resolved, and will be used to further improve the products as they are redesigned to production.

Attachment 4: Performance Matrix

Metric	Units	HECT 1.0 Baseline	HECT 2.1	HECT 2.2
Date range	Date	2018/06/05 – 2020/11/26	2019/09/25 – 2022/02/14	2019/10/02 – 2021/09/29
Number of total days recorded	Days	232.0	184.0	170.0
In-service days with >5 mile	Days	150.0	68.0	89.0
Max daily distance	mi	397.75	347.42	397.76
Avg daily distance	mi	53.33	22.69	24.00
Avg driving time	hr	1.75	0.81	0.89
Avg speed	mph	11.63	10.48	9.11
Avg driving speed (speed>0)	mph	29.21	25.93	24.30
Avg stops/day	stops / day	87.28	43.74	57.64
Avg stops/mi	stops / mi	1.64	1.93	2.40
Avg daily fuel use (CNG)	kg	50.73	13.82	15.37
Avg daily fuel use (diesel equiv.)	gal	17.52	4.78	5.32
Avg fuel economy (diesel equiv.)	mi / gal	4.06	4.75	4.52
Avg CNG Engine efficiency	%	22.64	26.04	25.20

V O L V O



FINAL REPORT

Greenhouse Gas Reduction Fund

Project ULTRA

CARB Grant #G14-LCTI-09

SCAQMD Contract # 17225

Modifications #17225-1 to 3

April 2022

DEVELOPMENT & DEMONSTRATION OF THREE CLASS 8 PLUG-IN HYBRID AND TWO CLASS 8 BATTERY ELECTRIC DRAYAGE TRUCKS

CONTENTS

ACRONYMS4

1.0 Introduction5

 1.1 Photos of truck developed in the project.....6

2.0 PRIMARY COMPONENT #1: PHEV trucks #2 and #3 with mini-burner PEMS TESTING.....10

 2.1 Background.....10

 2.2 Findings from PHEV Development and Demonstration11

 2.3 PEMS TESTING SUMMARY.....11

 2.3.1 PEMS testing in morgantown, wv12

 2.3.2 PEMS testing in long beach, ca.....16

 2.3.2.1 Heavy-Weight Configuration Results16

 2.3.2.2 Light-Weight Configuration Results22

 2.3.3 Conclusions from Development (Morgantown, WV) and Demonstration Testing (Long Beach, CA)25

 2.4 Findings from Mini-Burner Demonstration25

3.0 PRIMARY COMPONENT #2 – POWERTRAIN SOFTWARE PHEV XECU28

 3.1 Electric Geofence Maps.....28

 3.2 Issues Faced during Development:30

 3.3 CONCLUSIONS31

4.0 PRIMARY COMPONENT #3: ECO-DRIVE32

 4.1 Background.....32

 4.2 Eco-Drive Development and Demonstration32

 4.3 Eco-Drive Deployment on PHEV33

 4.4 Eco-Drive Simulation-Based Evaluation34

 4.5 Conclusions35

5.0 PRIMARY COMPONENT #4: Deploy 2 bev tractors36

 5.1 introduction.....36

 5.2 current operations36

 5.2.1 Preparing the Delivery.....37

 5.2.2 Delivery38

 5.2.3 Delivery Operations.....38

 5.3 Overall Fleet Operations38

 5.3.1 Maintenance Technicians.....38

 5.3.2 charging infrastructure.....39

 5.4 Coordination and Communication with Stakeholders39

5.5 Future Proofing39

5.6 Understanding Customer Operations40

5.7 Managing Expertise and Control40

5.8 existing software overview41

5.8.1 Numeric41

5.8.2 Paragon41

5.8.3 Custom Software41

5.8.4 Verizon Connect41

5.8.5 Dossier41

5.9 EV SPecific software applications42

5.9.1 Objectives and Requirements42

5.9.2 Software Features42

5.10 Data overview44

5.10.1 Methodology44

5.10.2 Analysis and Results45

5.10.3 Restrictions47

5.10.4 Anticipated Impact47

5.11 Workflow Changes48

5.11.1 Route Assignment and Truck Monitoring48

5.11.2 Pre- and Post-trip Inspections48

5.11.3 EV Maintenance48

5.11.4 Learning Curve49

5.12 Future Outlook49

6.0 PROJECT SUMMARY ANALYSIS REQUESTS50

6.1 operations in Dacs50

6.2 job creation51

7.0 APPENDICES-Addendums52

ACRONYMS

AC	Alternating Current
AER	All Electric Range
AHJ	Authority Having Jurisdiction
AMT	Automated Manual Transmission
BEV	Battery Electric Vehicle
CAFEE	Center for Alternative Fuels, Engines, and Emissions
CAN	Controller Area Network
CARB	California Air Resources Board
CFR	Code of Federal Regulations
C-ITS	coordinated intelligent transportation system
CO	Carbon Monoxide
CO ₂	Carbon Dioxide
COV	Coefficient of Variation
DC	Direct Current
DOC	Diesel Oxidation Catalyst
DPF	Diesel Particulate Filter
EATS	Emissions Aftertreatment System
ECU	Engine Control Unit
EPA	Environmental Protection Agency
ESS	Energy Storage System
FRATIS	Freight Advanced Traveler Information System
GGRF	Greenhouse Gas Reduction Fund
GHG	Greenhouse Gas
GPS	Global Positioning System
ICE	Internal Combustion Engine
NO	Nitric Oxide
NO _x	Oxides of Nitrogen
PC	Personal Computer
PEMS	portable emission measurement system
PHEV	Plug-In Hybrid Vehicle
SCAQMD	South Coast Air Quality Management District
SCR	Selective Catalytic Reduction (filter)
Sox	Sulfuric Oxides
SJVAPCD	San Joaquin Air Pollution Control District
SW	Software
TEMS	Transportable Emissions Measurement System
THC	Total Hydrocarbons
UCR	University of California Riverside
ULNOX	Ultra-Low NO _x
ULSD	Ultra-Low Sulfur Diesel
UPS	Uninterruptable Power Supply
USB	Universal Serial Bus
VOC	Volatile Organic Compounds
WVU	West Virginia University
XECU	Experimental Engine Control Unit

1.0 INTRODUCTION

This report will present the high level findings from the primary elements of the project.

- 1) PHEV truck operations
- 2) XECU Drivetrain Software
- 3) Eco-Drive
- 4) BEV deployment

The contract summarized the purpose and objectives for the project:

“The purpose of this project is to accelerate deployment of zero and near zero emission cargo transport technologies to reduce harmful diesel emissions, petroleum consumption and greenhouse gases in environmental justice communities along the goods movement corridors that are impacted by heavy diesel truck traffic and the associated air pollution. This project consists of the development and demonstration of plug-in hybrid electric drayage trucks in goods movement operations between ports throughout California and rail yards, intermodal facilities, and warehouses.

The objective of this project is to continue development of a Class-8 heavy-duty plug-in diesel hybrid electric vehicle (PHEV) drayage truck in order to demonstrate further reductions in fuel consumption, greenhouse gas, and criteria emissions in real world usage patterns. [Volvo will develop] additional refinements of the geo-fencing, driver information and hybrid controls features developed in an earlier project and will add additional project content to address very low NOx emissions levels when in nonzero emission modes, and demonstration of a coordinated intelligent transportation system (C-ITS) concept to coordinate vehicle operation with traffic flow and traffic signals to further reduce fuel consumption and emissions. “

Although there were two phases to the project implementation, this report will consider the project as a whole, and focus on the achievement of the project goals and the learning that can be carried forward into future projects and commercial Class 8 trucks. As defined in the contract, the project goals are:

“[Volvo] will [develop] a PHEV truck and related features that will demonstrate:

- A reduction in GHG and criteria emissions of up to 40% in pre-defined drayage duty cycles
- The ability to operate in zero-emissions mode
- The ability to significantly reduce GHG and criteria pollutant emissions in other locations and cycles where full electric heavy duty vehicles are not possible or practical
- Demonstrable C-ITS traffic flow solution for optimizing freight efficiency in the state of California where emissions benefits will be documented
- Exhaust after-treatment that provide[s] an opportunity for emissions improvements of both the blended mode and diesel engine mode
- A commercialization path that could make this technology successful in the marketplace

[Volvo] shall also demonstrate a new Class 8 truck that incorporates the above developments and refinements along with:

- An advanced second generation hybrid driveline with [Volvo’s] newest 11L engine packaged into a day-cab chassis
- Integration of a new larger capacity electric vehicle battery to increase all-electric range (AER)
- Integration of second generation high voltage components to reduce size and cost.”

The most recent modification to the contract added BEV deployment tasks:

“[Volvo] shall also deploy two Class 8 VNR battery electric drayage trucks at a fleet domiciled in the San Joaquin Valley Air Pollution Control District during 2021, along with depot fast charging infrastructure and a novel service concept to maximize equipment uptime using connected technologies.

1.1 PHOTOS OF TRUCK DEVELOPED IN THE PROJECT

PHEV #1



PHEV #1



PHEV #2



PHEV #2



PHEV #1 and PHEV #2 with Catenary Demo truck (from a different project) in-between



PHEV #3 testing in Morgantown at CAFEE Lab



PHEV #3



Producers Dairy BEVs at Fresno facility



2.0 PRIMARY COMPONENT #1: PHEV TRUCKS #2 AND #3 WITH MINI-BURNER PEMS TESTING

The development and refinement of PHEV drivetrains was a significant element of the project. In addition, the project tested emissions aftertreatment systems (EATS) in the form of a mini-burner which would maintain catalyst temperature to improve hybrid emissions performance. That EATS was put through testing with a Portable Emissions Measurement System (PEMS) by West Virginia University (WVU).

2.1 BACKGROUND

The concept trucks PHEV#2 and PHEV #3 truck are part of Volvo's Ultra Low NOx (ULNOX) project co-funded by South Coast Air Quality Management District (SCAQMD) and California Air Resources Board (CARB) under the Greenhouse Gas Reduction Fund (GGRF) program, part of the California Climate Initiatives project putting Cap and Trade Dollars to Work. This particular project focused on the integration of low NOx exhaust aftertreatment

technology, plug-in hybrid technology, and connectivity in order to minimize in-use tailpipe Greenhouse Gas (GHG) and criteria pollutant emissions. PHEV #2 and PHEV #3, just like the predecessor PHEV #1, will help accelerate development of technologies necessary to achieve near-zero and zero emission in Class 8 Heavy Duty Trucks Industry.

The goal of the ULNOX (a.k.a ULTRA) project was to demonstrate two Class 8 heavy-duty plug-in hybrid drayage trucks in revenue service in the San Pedro Bay ports. PHEV #1, which Volvo developed together with South Coast AQMD under a previous DOE co-funded project, was used as engineering mule by Volvo during the first half of this project. PHEV #2 (Mack Pinnacle) was deployed and completed revenue service in August 2017. PHEV #3 was tested first at Volvo's engineering campuses in Greensboro, NC and Hagerstown, MD to prepare for its demonstration phase, then the hybrid PHEV #3 with the mini-burner Exhaust Aftertreatment System (EATS) was tested at West Virginia University and on local roads. These initial tests provided an opportunity to prove out the vehicle with all agreed upon elements of the Ultra-Low NOx concept as initially proposed. Once the mini-burner technology on PHEV #3 was commissioned and validated for emission reductions, PHEV #3 was transported to UC Riverside to confirm implementation, performance, and robustness of the connected intelligent transportation system (C-ITS) Eco-Drive technology while operating on the connected freight corridors. PHEV #3 was then handed over to the TEC Equipment dealership in La Mirada, CA for pre-delivery inspection, registration, and delivery to the test fleet Intermodal Bridge Transport (IBT). PHEV #3 was deployed in daily operation revenue service as part of the drayage fleet at IBT in Southern California for the final customer operation and evaluation.

2.2 FINDINGS FROM PHEV DEVELOPMENT AND DEMONSTRATION

Emission analysis was performed to quantify the emission benefits of the mini-burner system under semi-controlled conditions. This evaluation employed a combination of WVU's CAFEE chassis dynamometer and local road cycles defined earlier in the project, or a combination of both. Emissions data was collected using the typical CAFEE equipment and methods and compared with baseline tests performed on the mule PHEV (PHEV#1) earlier in this project in order to the quantify GHG and NOx emission impacts.

The team also performed on-road testing on local routes emulating drayage operation, which were developed jointly by Volvo and WVU earlier in this program. Emissions data was collected by WVU using PEMS and the results were compared to previous PEMS measurements of the mule PHEV truck on the same routes.

The performance and robustness of the mini-burner concept was evaluated during approximately 5 months of field testing at IBT, a port drayage fleet based on Long Beach, CA. During this time Volvo and the customer supported data collection by WVU, CARB and Ricardo, including the instrumentation and measurement of tailpipe emissions using a Portable Emissions Measurement System (PEMS).

2.3 PEMS TESTING SUMMARY

The West Virginia University Center for Alternative Fuels, Engines, and Emissions (CAFEE) conducted in-use emission measurements of PHEV #3 with mini-burner technology for emission control enhancement. Real-world testing was performed over three prescribed test routes, including an extended stop-and-go activity, while gaseous emissions of CO₂, NO_x, CO and THC were quantified using a portable emission measurement system (PEMS). PEMS Data were recorded from on-board sensors and software continuously using high-resolution proprietary data recording equipment.. It should be noted that Volvo and WVU already performed PEMS measurement of PHEV#2

and of an equivalent baseline Diesel Drayage truck in November 2017, which provided a valuable reference point for PHEV #3 PEMS testing.

In Morgantown WV – home of WVU, four (4) different routes were used during the project to evaluate the operation of the test vehicle. Each route started and returned to the CAFEE’s Vehicle and Engine Testing Laboratory (VETL) in Morgantown, WV. The test vehicle also stopped in the ‘Mixed’ and ‘Stop-and-Go’ routes such that the analyzers could undergo a zero and span check during the test. This was specifically done for these two routes as the test duration was

In Morgantown, the vehicle was tested with two (2) overall combined weight configuration (i.e., truck and trailer), including i) a full load configuration at 64,300lbs and ii) a low-load configuration at 31,900lbs. For both configurations, the test truck was connected to a flatbed trailer, loaded with concrete blocks to simulate weight for the first configuration, and empty to represent the test weight for the second configuration.

In Long Beach, CA – a major national port city, three (3) different test routes were developed for this program to characterize diverse drayage truck operation between the Ports of Long Beach and Los Angeles and inland warehouses and railyards. The WVU CAFEE had previously installed activity data loggers on various port drayage trucking companies’ vehicles for a South Coast Air Quality Management District (SCAQMD) funded program. The wealth of real-world activity data from the SCAQMD program was leveraged to derive the three (3) test routes for the testing of PHEV 3.

Two of the test routes were characterized by Neardock and regional drayage operation, simulating delivery of containerized loads from the ports to warehouses in the Inland Empire and the San Fernando Valley. In addition, the San Fernando Valley regional drayage route comprises an approximate 1200ft hill-climb on Freeway 405. The third route was characterized by Neardock and local operation with simulated deliveries for cargo container from the ports to local warehouses and railyards. It must be noted that even though the developed test routes simulated wait-time for loading/unloading of containers/loads at the port and destination warehouses from an activity dynamic standpoint (i.e., low-speed creep operation and extended idle), the actual weight of the TEMS that simulated the test load was always remaining the same.

During this study, Total Transportation Services Inc.(TTSI) has kindly provided WVU with the opportunity to stage the TEMS at one of their fleet yards in Carson, CA. The three routes designed for this study all started and ended at TTSI’s fleet yard., which more realistically simulates the start and end-points of drayage truck operation by an actual fleet.

2.3.1 PEMS TESTING IN MORGANTOWN, WV

Data from the PHEV #3 PEMS testing that was collected over four test routes at two combined vehicle weight configurations are presented with respect to percent differences in Table 2.1 These data are graphically presented in Figure 2.1, with data marker size (small and large) corresponding to the combined vehicle test weight, while marker color is used to differentiate test route (green=highway, red=city, blue=mixed and yellow=stop-and-go). For this figure, marker shape is used to indicate one of the three emissions control strategy configurations, namely,

1. Diesel-only operation with no mini-burner (circle marker)
2. Diesel-only operation with mini-burner (triangle marker)
3. hybrid operation with mini-burner (square marker)

It is noted that hybrid operation without mini-burner was not selected as a test configuration, nor was diesel-only operation with the mini-burner not activated tested over the highway test route for either combined test weight configuration. A compilation of route-averaged results and relevant statistics are included in Table 2.2.

Comparison of Diesel-Only Operations

As Figure 2.1 indicates, for diesel-only operation, the implementation of the mini-burner reduced route-averaged NO_x emissions across all test routes and combined vehicle test weights, with performance ranging from ~50%-90% reduction (see Table 2.1). This improved NO_x control was realized with varied effects on CO and THC tailpipe emissions, with relatively no apparent correlation with engine load, due to route or combined test weight. The location of the mini-burner, upstream of the inlet to the emissions aftertreatment system (EATS), would increase catalyst temperatures for NO_x conversion as well as CO and THC. PEMS results indicated some reductions in CO and THC at different combined test weights and across some of the test routes, however there were combinations of test conditions that resulted in increased CO and THC emissions. The inconsistent control is likely attributed to insufficient control strategy optimization of the burner and the challenges of distributing the thermal energy generated by the mini-burner across catalyst substrates during low exhaust flowrate engine operation. In addition, the already low levels of these constituents in Diesel exhaust and the inherent coefficient of variance (COV) of the measurements could exacerbate small changes in route-averaged emissions rates. As expected, the operation of the mini-burner resulted in net increase of fuel use, ranging from ~3%-6.5%. For the high combined test weight tests involving the Mixed route and the low combined test weight of the Stop-and-Go route, activation of the mini-burner resulted in reduced route-averaged CO₂ emissions, which is obviously counter-intuitive. However, the COV of the CO₂ data for these tests were considerably higher than normally encountered for PEMS testing (~7%-9%).

Comparison of Hybrid to Diesel Operation

Hybrid operation with the mini-burner resulted in reduced CO₂ emissions, compared to both diesel-only with- and without the mini-burner, across all test routes and combined vehicle test weights. Hybrid operation with the mini-burner reduced NO_x emissions when compared to diesel-only operation without the mini-burner for the three test routes at the lower combined vehicle load. As Table 2.1 indicates, this trend did not predominantly transition into the higher load testing for NO_x emissions control. When comparing hybrid and diesel-only operation with the mini-burner technology activated, tailpipe NO_x emissions were increased substantially (over an order of magnitude). This result is attributed to the additional thermal management challenges introduced by hybrid operation. Not only is thermal energy removed from the EATS, but during operation when the engine is decoupled and remains at idle, the EATS is effectively cooled by the low thermal quality combustion exhaust. The challenges associated with hybrid operation, with control optimizing battery energy levels and reduced tailpipe GHG, presented considerable challenges with respect to thermal management of NO_x emissions control catalysts. Additional commentary and analysis of the overall efficacy of the mini-burner technology is discussed in the section below. As expected, hybrid operation did result in reduced CO₂ tailpipe emissions for all test configurations and test routes, when compared to diesel-only operation with and without the assistance of the mini-burner. CO emissions collected during hybrid operation were lower than those measured during diesel-only operation, both with and without mini-burner, across all routes tested at the high combined vehicle weights. However, although counter-intuitive, CO and THC emissions were observed to increase for some combined test weights and test routes. As mentioned above, low levels of these constituents in Diesel exhaust and the inherent coefficient of variation (COV) of the measurements could exacerbate small changes in route-averaged emissions rates.

Table 2.1 Comparison of route-averaged emissions performance between technologies

	Diesel w/Mini-Burner vs. Diesel					Hybrid w/Mini-Burner vs. Diesel					Hybrid w/Mini-Burner vs. Diesel w/Mini-Burner			
	ds_mCO2	ds_mCO	ds_mNOx	ds_mTHC		ds_mCO2	ds_mCO	ds_mNOx	ds_mTHC		ds_mCO2	ds_mCO	ds_mNOx	ds_mTHC
	[g/mile]	[g/mile]	[g/mile]	[g/mile]		[g/mile]	[g/mile]	[g/mile]	[g/mile]		[g/mile]	[g/mile]	[g/mile]	[g/mile]
Highway					Highway					Highway	-1.5%	-20.5%	288.9%	192.0%
City	3.7%	6.2%	-51.5%	-19.7%	City	-5.4%	-33.7%	89.2%	93.6%	City	-8.8%	-37.5%	289.7%	141.0%
Mixed	-4.0%	-41.9%	-83.0%	-24.6%	Mixed	-9.4%	-51.4%	-8.6%	-26.7%	Mixed	-5.6%	-16.2%	437.2%	-2.8%
Stop-and-Go	3.3%	-27.2%	-79.7%	17.2%	Stop-and-Go	-2.7%	-54.1%	3.5%	-46.7%	Stop-and-Go	-5.9%	-36.9%	410.9%	-54.5%
Highway					Highway					Highway	-5.1%	397.5%	278.8%	488.0%
City	6.5%	-60.1%	-84.5%	19.4%	City	-9.8%	-67.6%	-54.2%	17.7%	City	-15.3%	-18.7%	196.5%	-1.5%
Mixed	4.9%	123.5%	-85.0%	-46.1%	Mixed	-0.8%	313.5%	-59.9%	-31.9%	Mixed	-5.4%	85.0%	167.2%	26.3%
Stop-and-Go	-1.6%	-30.6%	-89.0%	-7.1%	Stop-and-Go	-15.9%	-40.2%	-65.3%	-28.2%	Stop-and-Go	-14.6%	-13.8%	216.0%	-22.7%

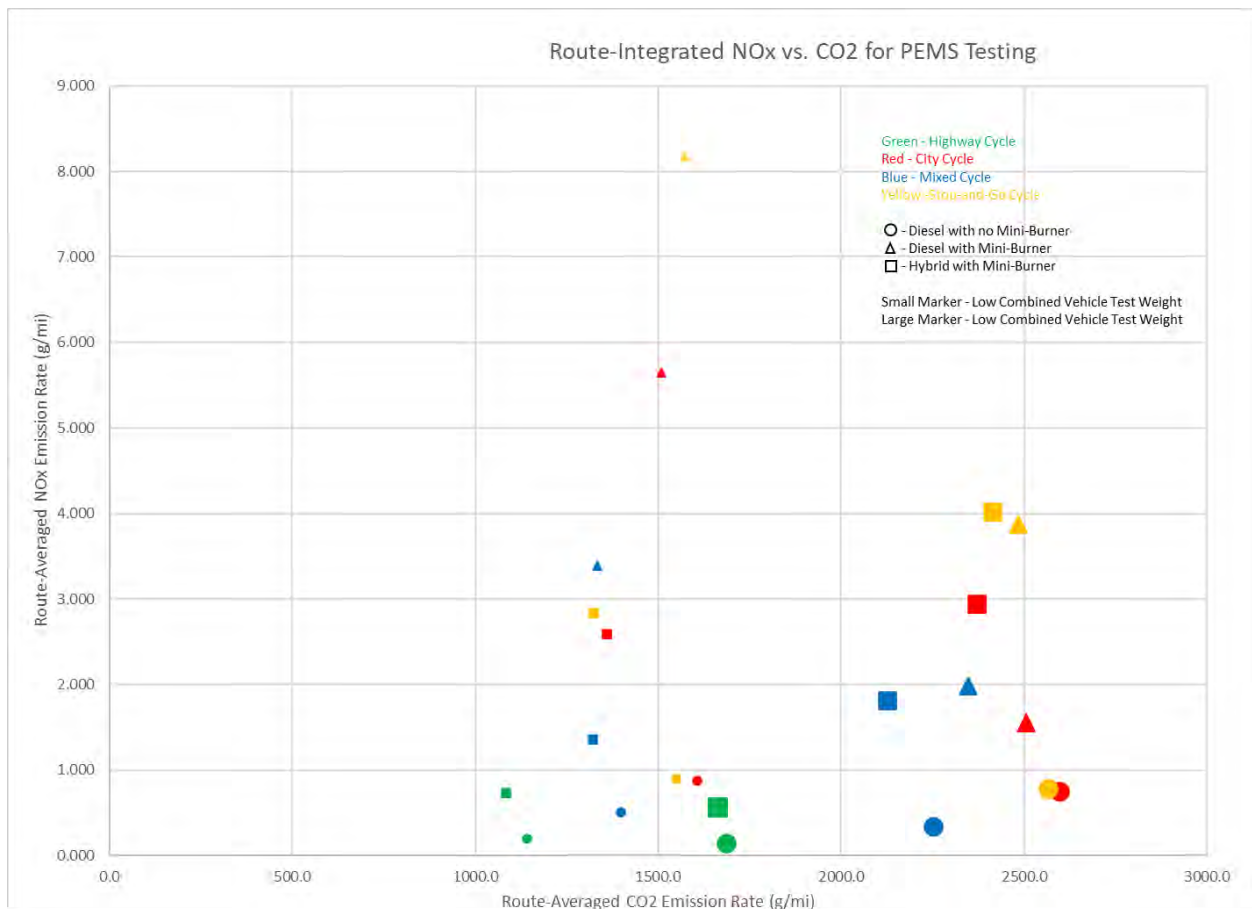

Figure 2.1 Route-averaged NOx emissions vs. route-averaged CO₂ emissions for two combined vehicle test weights over four test routes during Morgantown PEMS testing.

Table 2.2 Route-averaged emissions data from the PEMS testing conducted in Morgantown, WV

		Diesel Only Mode								Diesel-Electric Hybrid Mode						
		Mini-Burner ON				Mini-Burner OFF				Mini-Burner ON						
		ds_mCO2	ds_mCO	ds_mNOx	ds_mTHC	ds_mCO2	ds_mCO	ds_mNOx	ds_mTHC	ds_mCO2	ds_mCO	ds_mNOx	ds_mTHC			
		[g/mile]	[g/mile]	[g/mile]	[g/mile]	[g/mile]	[g/mile]	[g/mile]	[g/mile]	[g/mile]	[g/mile]	[g/mile]	[g/mile]			
Full Test Weight	Highway	(n=2)				(n=0)				(n=2)						
		Average	1686.4	0.419	0.146	0.007	Average				Average	1661.6	0.333	0.566	0.021	
		Stdev	11.9	0.098	0.053	0.001	Stdev				Stdev	14.8	0.030	0.273	0.002	
		COV [%]	0.71	23.48	36.68	8.81	COV [%]				COV [%]	0.89	8.95	48.27	9.23	
	City	(n=5)					(n=3)				(n=11)					
		Average	2597.3	1.434	0.755	0.027	Average	2504.7	1.350	1.555	0.033	Average	2369.8	0.896	2.943	0.065
		Stdev	86.0	0.455	0.105	0.007	Stdev	110.8	0.746	0.757	0.018	Stdev	182.0	0.113	0.757	0.138
		COV [%]	3.31	31.70	13.86	25.90	COV [%]	4.42	55.25	48.66	52.69	COV [%]	7.68	12.56	25.74	213.97
	Mixed	(n=3)					(n=2)				(n=5)					
		Average	2252.1	0.974	0.337	0.017	Average	2346.5	1.678	1.982	0.023	Average	2126.1	0.816	1.813	0.017
		Stdev	205.3	0.222	0.147	0.005	Stdev	417.9	0.050	0.373	0.006	Stdev	185.7	0.284	0.811	0.019
		COV [%]	9.11	22.83	43.69	26.96	COV [%]	17.81	3.00	18.80	27.06	COV [%]	8.73	34.85	44.72	110.88
Stop-and-Go	(n=2)					(n=2)				(n=2)						
	Average	2565.9	1.335	0.785	0.024	Average	2483.5	1.834	3.876	0.020	Average	2415.2	0.843	4.013	0.011	
	Stdev	122.5	0.153	0.256	0.002	Stdev	18.6	0.288	2.526	0.000	Stdev	495.7	0.190	0.563	0.011	
	COV [%]	4.77	11.47	32.55	10.39	COV [%]	0.75	15.71	65.17	1.41	COV [%]	20.52	22.55	14.04	100.55	
Low Test Weight	Highway	(n=3)				(n=0)				(n=2)						
		Average	1142.0	0.088	0.194	0.001	Average				Average	1083.4	0.440	0.735	0.007	
		Stdev	3.8	0.115	0.112	0.001	Stdev				Stdev	8.1	0.274	0.650	0.001	
		COV [%]	0.33	130.52	57.60	92.23	COV [%]				COV [%]	0.74	62.28	88.44	14.51	
	City	(n=10)					(n=2)				(n=10)					
		Average	1607.2	0.706	0.873	0.021	Average	1508.4	1.773	5.649	0.017	Average	1360.8	0.575	2.590	0.020
		Stdev	79.8	0.571	0.530	0.009	Stdev	29.2	0.723	0.206	0.002	Stdev	135.5	0.354	1.219	0.007
		COV [%]	4.96	80.81	60.68	45.51	COV [%]	1.93	40.79	3.64	10.62	COV [%]	9.96	61.54	47.06	33.11
	Mixed	(n=6)					(n=1)				(n=5)					
		Average	1396.9	0.620	0.508	0.014	Average	1332.3	0.277	3.388	0.026	Average	1321.4	1.147	1.358	0.018
		Stdev	135.3	0.395	0.283	0.006	Stdev	213.4	0.065	0.556	0.010	Stdev	164.8	0.670	0.615	0.005
		COV [%]	9.68	63.73	55.61	38.79	COV [%]	16.01	23.34	16.42	38.11	COV [%]	12.47	58.41	45.29	27.40
Stop-and-Go	(n=3)					(n=1)				(n=3)						
	Average	1549.0	0.761	0.898	0.017	Average	1573.8	1.096	8.172	0.019	Average	1323.6	0.656	2.837	0.013	
	Stdev	114.9	0.451	0.560	0.002	Stdev	68.3	0.044	0.089	0.000	Stdev	420.1	0.407	0.586	0.001	
	COV [%]	7.42	59.22	62.40	13.54	COV [%]	4.34	4.06	1.09	1.11	COV [%]	31.74	61.99	20.67	9.61	

Note: (n=X) denotes the number of repeated test within a category
Stdev represents 1 x σ standard deviation

2.3.2 PEMS TESTING IN LONG BEACH, CA

2.3.2.1 HEAVY-WEIGHT CONFIGURATION RESULTS

A comparison of distance-specific emissions results from the control Diesel vehicle and PHEV#3 are included in Table 2.3 for the heavy combined vehicle weight testing.

Tailpipe NO_x emissions for the hybrid system were lower for cold segment testing across two of the three candidate routes, with the exception being the local drayage route, where increased NO₂ resulted in an ~18% increase in total NO_x emissions, although NO was reduced.

Measured CO₂ emissions were lower for the hybrid vehicle than for the diesel control vehicle for cold and warm start tests across all three candidate routes. For the hot tests of both regional routes, CO₂ tailpipe emissions were lower for the diesel control vehicle.

Although not as pronounced as those results from the Morgantown PEMS testing above, the hybrid strategy control seemed to limit catalyst thermal management benefits that were anticipated from the mini-burner technology, as evident by the disparity exhibited between the control diesel vehicle tailpipe emissions and those collected from the hybrid vehicle. This difference is attributed to the higher average load across those routes, combined with a sufficiently warm EATS.

A complete summary of results for heavy combined vehicle weight testing of both the PHEV#3 and candidate Diesel test results are included in Table 2.5- Table 2.8, below in both brake-specific and distance-specific formats.

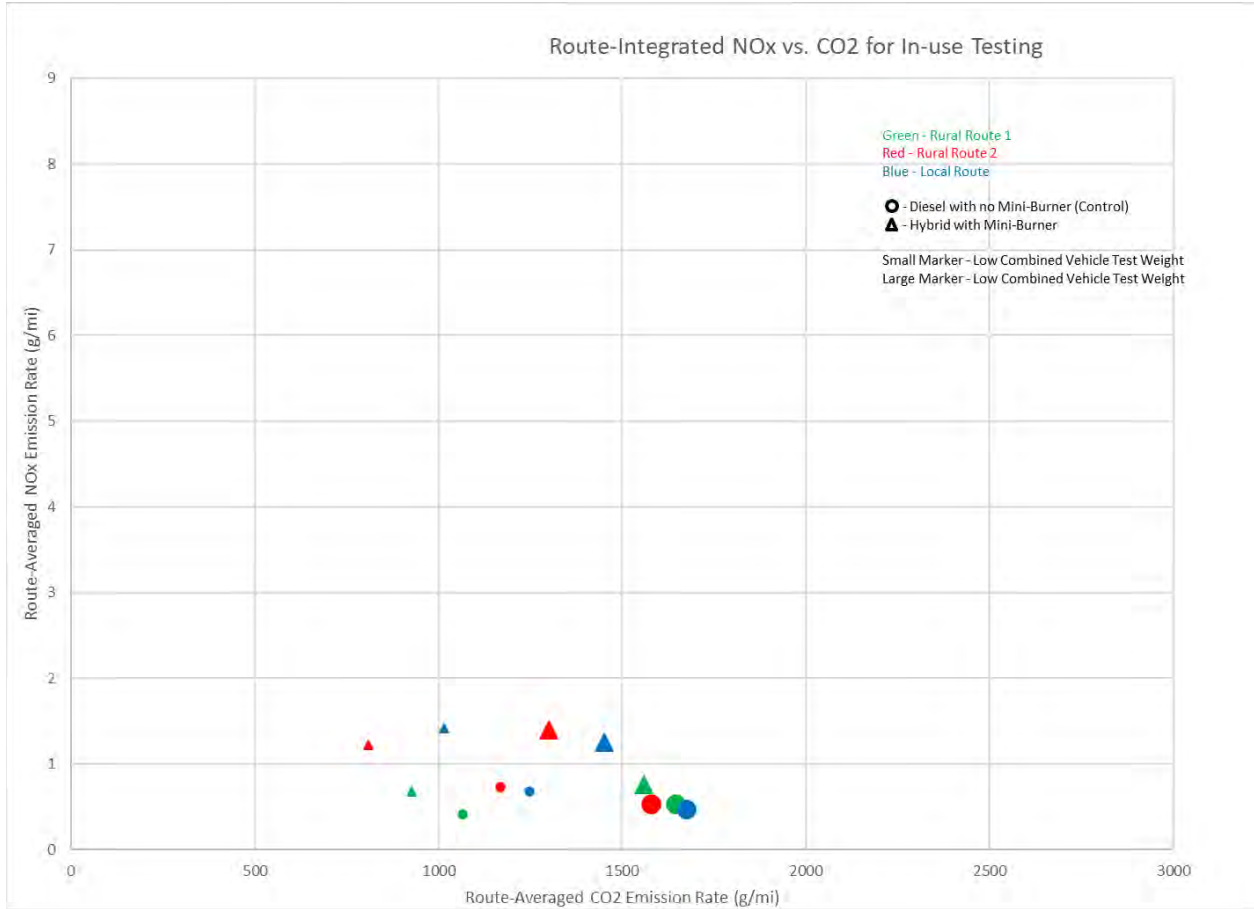

Figure 2.2 Route-averaged NOx emissions vs. route-averaged CO₂ emissions for two combined vehicle test weights over three test routes during Long Beach CA in-use testing.

Table 2.3 Comparison of route-averaged emissions performance between technologies for Long Beach CA in-use testing..

			THC	CH4	NMHC	NOx	NO	NO2	CO	CO2
			[g/mile]	[g/mile]	[g/mile]	[g/mile]	[g/mile]	[g/mile]	[g/mile]	[g/mile]
Heavy Combined Vehicle Test Weight	Composite Rural Route 1	Diesel	0.063	0.0304	0.0342	0.5317	0.464	0.0672	0.8798	1645.17
		Hybrid	0.0357	0.0023	0.0281	0.7587	0.4602	0.3003	0.7594	1559.68
		Difference	-43.3%	-92.4%	-17.8%	42.7%	-0.8%	346.9%	-13.7%	-5.2%
	Composite Rural Route 2	Diesel	0.0757	0.0009	0.0703	0.5322	0.4804	0.0513	0.8877	1578.08
		Hybrid	0.2709	0.1195	0.1138	1.3947	0.8573	0.5344	1.7922	1300.46
		Difference	257.9%	13177.8%	61.9%	162.1%	78.5%	941.7%	101.9%	-17.6%
	Composite Local Route	Diesel	0.0849	0.0133	0.0632	0.47	0.4201	0.0526	0.9365	1674.83
		Hybrid	0.2551	0.1669	0.0759	1.253	0.7887	0.4646	1.9732	1451.86
		Difference	200.5%	1154.9%	20.1%	166.6%	87.7%	783.3%	110.7%	-13.3%
			THC	CH4	NMHC	NOx	NO	NO2	CO	CO2
			[g/mile]	[g/mile]	[g/mile]	[g/mile]	[g/mile]	[g/mile]	[g/mile]	[g/mile]
Light Combined Vehicle Test Weight	Composite Rural Route 1	Diesel	0.0101	0.0029	0.0075	0.4159	0.008	0.8031	0.4613	1065.15
		Hybrid	0.0203	0.0028	0.0176	0.6801	0.1017	0.8021	0.5297	925.88
		Difference	101.0%	-3.4%	134.7%	63.5%	1171.3%	-0.1%	14.8%	-13.1%
	Composite Rural Route 2	Diesel	0.0258	0.0093	0.0172	0.731	0.0099	0.6637	0.4752	1167.78
		Hybrid	0.0076	0.004	0.0044	1.2252	0.4003	1.2366	0.4799	809.67
		Difference	-70.5%	-57.0%	-74.4%	67.6%	3943.4%	86.3%	1.0%	-30.7%
	Composite Local Route	Diesel	0.0239	0.0051	0.0192	0.6747	0.0188	0.8808	0.6297	1247.37
		Hybrid	0.0103	0.0072	0.0042	1.4133	0.4999	1.7336	0.5141	1016.2
		Difference	-56.9%	41.2%	-78.1%	109.5%	2559.0%	96.8%	-18.4%	-18.5%

Table 2.4 Comparison of control Diesel and hybrid emissions control technologies during the heavy combined vehicle weight emissions tests in Long Beach CA.

			THC	CH4	NMHC	NOx	NO	NO2	CO	CO2
			[g/mile]	[g/mile]	[g/mile]	[g/mile]	[g/mile]	[g/mile]	[g/mile]	[g/mile]
Regional Route 1	Segment 1 - Cold	Diesel	0.0922	0.3192	0	3.1863	2.7758	0.4108	1.997	2828.63
		Hybrid	0.1119	0.0094	0.0799	2.3926	0.9373	1.4548	0.7502	2006.95
		Difference	21.4%	-97.1%	#DIV/0!	-24.9%	-66.2%	254.1%	-62.4%	-29.0%
	Segment 2 - Hot	Diesel	0	0.0069	0	0.4321	0.3799	0.0524	0.7436	1737.07
		Hybrid	0.0535	0.0024	0.0443	0.9763	0.6977	0.2791	0.7648	1783.09
		Difference	#DIV/0!	-65.2%	#DIV/0!	125.9%	83.7%	432.6%	2.9%	2.6%
	Segment 2 - Warm	Diesel	0.1203	0	0.0744	0.1377	0.1182	0.0182	0.8076	1334.04
		Hybrid	0.0034	0.0008	0.0023	0.2184	0.139	0.0826	0.7564	1257.95
		Difference	-97.2%	#DIV/0!	-96.9%	58.6%	17.6%	353.8%	-6.3%	-5.7%
			THC	CH4	NMHC	NOx	NO	NO2	CO	CO2
			[g/mile]	[g/mile]	[g/mile]	[g/mile]	[g/mile]	[g/mile]	[g/mile]	[g/mile]
Regional Route 2	Segment 1 - Cold	Diesel	0.3002	0.0095	0.2514	2.2216	2.0371	0.1798	1.5825	2177.75
		Hybrid	0.8138	0.4266	0.335	2.079	0.9587	1.1225	3.8124	1560.73
		Difference	171.1%	4390.5%	33.3%	-6.4%	-52.9%	524.3%	140.9%	-28.3%
	Segment 2 - Hot	Diesel	0.0562	0	0.055	0.2266	0.2018	0.0247	0.7953	1485.21
		Hybrid	0.0535	0.0024	0.0443	0.9763	0.6977	0.2791	0.7648	1783.09
		Difference	-4.8%	#DIV/0!	-19.5%	330.8%	245.7%	1030.0%	-3.8%	20.1%
	Segment 2 - Warm	Diesel	0.0155	0	0.0152	2.0155	1.811	0.2055	1.0904	1914.01
		Hybrid	0.3082	0.2522	0.0523	2.7202	1.8584	0.8655	3.5822	1060.42
		Difference	1888.4%	#DIV/0!	244.1%	35.0%	2.6%	321.2%	228.5%	-44.6%
			THC	CH4	NMHC	NOx	NO	NO2	CO	CO2
			[g/mile]	[g/mile]	[g/mile]	[g/mile]	[g/mile]	[g/mile]	[g/mile]	[g/mile]
Local Route	Segment 1 - Cold	Diesel	0.0448	0	0.0415	0.4654	0.4238	0.0462	0.9254	1637.29
		Hybrid	0.2803	0.2424	0.0307	0.5506	0.2556	0.2971	1.8497	1382.32
		Difference	525.7%	#DIV/0!	-26.0%	18.3%	-39.7%	543.1%	99.9%	-15.6%
	Segment 2 - Hot	Diesel	0.0732	0.0068	0.0575	0.2614	0.2255	0.0369	0.9188	1646.3
		Hybrid	0.2196	0.1034	0.1006	1.5206	0.9377	0.5824	1.7876	1524.75
		Difference	200.0%	1420.6%	75.0%	481.7%	315.8%	1478.3%	94.6%	-7.4%
	Segment 2 - Warm	Diesel	0.3424	0.1138	0.1981	1.7507	1.5779	0.1773	1.0953	2021.61
		Hybrid	0.3505	0.2021	0.1321	2.8163	2.2922	0.5217	3.6088	1335.34
		Difference	2.4%	77.6%	-33.3%	60.9%	45.3%	194.2%	229.5%	-33.9%

Table 2.5 Candidate Diesel-electric hybrid vehicle, heavy-weight configuration, work-specific emissions rates over different test routes.

Test Routes		THC	CH4	NMHC	NOx	NO	NO2	CO	CO2
Regional Route 1		[g/bhp-hr]	[g/bhp-hr]	[g/bhp-hr]	[g/bhp-hr]	[g/bhp-hr]	[g/bhp-hr]	[g/bhp-hr]	[g/bhp-hr]
Segment 1	Cold	0.0284	0.0024	0.0203	0.6069	0.2378	0.3690	0.1903	509.08
Segment 2	Hot	0.0142	0.0006	0.0117	0.2587	0.1849	0.0740	0.2027	472.51
Segment 2	Warm	0.0012	0.0003	0.0009	0.0809	0.0515	0.0306	0.2802	466.07
Total		0.0109	0.0007	0.0086	0.2307	0.1399	0.0913	0.2309	474.25
Regional Route 2									
Segment 1	Cold	0.2121	0.1112	0.0873	0.5418	0.2498	0.2925	0.9935	406.75
Segment 2	Hot	0.0688	0.0245	0.0314	0.4030	0.2547	0.1470	0.4718	432.19
Segment 2	Warm	0.0973	0.0796	0.0165	0.8588	0.5867	0.2732	1.1309	334.77
Total		0.0879	0.0388	0.0369	0.4527	0.2783	0.1734	0.5817	422.08
Local Route									
Segment 1	Cold	0.0845	0.0730	0.0093	0.1659	0.0770	0.0895	0.5574	416.58
Segment 2	Hot	0.0666	0.0314	0.0305	0.4612	0.2844	0.1767	0.5422	462.50
Segment 2	Warm	0.0991	0.0571	0.0374	0.7965	0.6482	0.1475	1.0206	377.64
Total		0.0767	0.0502	0.0228	0.3767	0.2371	0.1397	0.5932	436.47

Table 2.6: Candidate Diesel-electric hybrid vehicle, heavy-weight configuration, distance-specific emissions rates over different test routes.

Test Routes		THC	CH4	NMHC	NOx	NO	NO2	CO	CO2
Regional Route 1		[g/mile]	[g/mile]	[g/mile]	[g/mile]	[g/mile]	[g/mile]	[g/mile]	[g/mile]
Segment 1	Cold	0.1119	0.0094	0.0799	2.3926	0.9373	1.4548	0.7502	2006.95
Segment 2	Hot	0.0535	0.0024	0.0443	0.9763	0.6977	0.2791	0.7648	1783.09
Segment 2	Warm	0.0034	0.0008	0.0023	0.2184	0.1390	0.0826	0.7564	1257.95
Total		0.0357	0.0023	0.0281	0.7587	0.4602	0.3003	0.7594	1559.68
Regional Route 2									
Segment 1	Cold	0.8138	0.4266	0.3350	2.0790	0.9587	1.1225	3.8124	1560.73
Segment 2	Hot	0.2056	0.0731	0.0938	1.2039	0.7608	0.4390	1.4093	1291.06
Segment 2	Warm	0.3082	0.2522	0.0523	2.7202	1.8584	0.8655	3.5822	1060.42
Total		0.2709	0.1195	0.1138	1.3947	0.8573	0.5344	1.7922	1300.46
Local Route									
Segment 1	Cold	0.2803	0.2424	0.0307	0.5506	0.2556	0.2971	1.8497	1382.32
Segment 2	Hot	0.2196	0.1034	0.1006	1.5206	0.9377	0.5824	1.7876	1524.75
Segment 2	Warm	0.3505	0.2021	0.1321	2.8163	2.2922	0.5217	3.6088	1335.34
Total		0.2551	0.1669	0.0759	1.2530	0.7887	0.4646	1.9732	1451.86

Table 2.7: Control Diesel vehicle, heavy-weight configuration, work-specific emissions rates over different test routes.

Test Routes		THC	CH4	NMHC	NOx	NO	NO2	CO	CO2
Regional Route 1		[g/bhp-hr]	[g/bhp-hr]	[g/bhp-hr]	[g/bhp-hr]	[g/bhp-hr]	[g/bhp-hr]	[g/bhp-hr]	[g/bhp-hr]
Segment 1	Cold	0.0181	0.0626	0.0000	0.6243	0.5439	0.0805	0.3913	554.22
Segment 2	Hot	0.0000	0.0018	0.0000	0.1101	0.0968	0.0133	0.1895	442.63
Segment 2	Warm	0.0400	0.0000	0.0248	0.0458	0.0394	0.0061	0.2689	444.13
Total		0.0175	0.0084	0.0095	0.1476	0.1288	0.0187	0.2442	456.68
Regional Route 2									
Segment 1	Warm	0.0722	0.0023	0.0605	0.5341	0.4898	0.0432	0.3805	523.60
Segment 2	Hot	0.0165	0.0000	0.0162	0.0665	0.0593	0.0072	0.2336	436.15
Segment 2	Warm	0.0039	0.0000	0.0038	0.5072	0.4557	0.0517	0.2744	481.64
Total		0.0215	0.0002	0.0200	0.1515	0.1367	0.0146	0.2527	449.16
Local Route									
Segment 1	Cold	0.0124	0.0000	0.0115	0.1285	0.1170	0.0128	0.2556	452.15
Segment 2	Hot	0.0194	0.0018	0.0152	0.0693	0.0598	0.0098	0.2436	436.42
Segment 2	Warm	0.0806	0.0268	0.0466	0.4121	0.3714	0.0417	0.2578	475.87
Total		0.0226	0.0035	0.0168	0.1252	0.1119	0.0140	0.2496	446.28

Table 2.8: Control Diesel vehicle, heavy-weight configuration, distance-specific emissions rates over different test routes.

Test Routes		THC	CH4	NMHC	NOx	NO	NO2	CO	CO2
Regional Route 1		[g/mile]	[g/mile]	[g/mile]	[g/mile]	[g/mile]	[g/mile]	[g/mile]	[g/mile]
Segment 1	Cold	0.0922	0.3192	0.0000	3.1863	2.7758	0.4108	1.9970	2828.63
Segment 2	Hot	0.0000	0.0069	0.0000	0.4321	0.3799	0.0524	0.7436	1737.07
Segment 2	Warm	0.1203	0.0000	0.0744	0.1377	0.1182	0.0182	0.8076	1334.04
Total		0.0630	0.0304	0.0342	0.5317	0.4640	0.0672	0.8798	1645.17
Regional Route 2									
Segment 1	Warm	0.3002	0.0095	0.2514	2.2216	2.0371	0.1798	1.5825	2177.75
Segment 2	Hot	0.0562	0.0000	0.0550	0.2266	0.2018	0.0247	0.7953	1485.21
Segment 2	Warm	0.0155	0.0000	0.0152	2.0155	1.8110	0.2055	1.0904	1914.01
Total		0.0757	0.0009	0.0703	0.5322	0.4804	0.0513	0.8877	1578.08
Local Route									
Segment 1	Cold	0.0448	0.0000	0.0415	0.4654	0.4238	0.0462	0.9254	1637.29
Segment 2	Hot	0.0732	0.0068	0.0575	0.2614	0.2255	0.0369	0.9188	1646.30
Segment 2	Warm	0.3424	0.1138	0.1981	1.7507	1.5779	0.1773	1.0953	2021.61
Total		0.0849	0.0133	0.0632	0.4700	0.4201	0.0526	0.9365	1674.83

2.3.2.2 LIGHT-WEIGHT CONFIGURATION RESULTS

A comparison of distance-specific emissions results from the control Diesel vehicle and PHEV#3 are included in Table 2.9 for the light combined vehicle weight testing.

Tailpipe emissions for all measured constituents, with the exception of NO₂, measured from the hybrid system were lower for cold segment testing across the two reported candidate routes. For the warm segment of Regional Route 2, nearly all emissions were measurably lower, with the exception of CH₄ and NO₂. For the hot segment of Regional Route 2, only NO_x and CO emissions exhibited an increase when comparing hybrid vehicle tailpipe emissions to those of the Diesel control vehicle. For hot testing across both candidate routes, the control diesel vehicle produced lower tailpipe emissions, with the exception of THC, CH₄, NMHC and CO₂ for Regional Route 2.

A complete summary of results for light combined vehicle weight testing of both the PHEV#3 and candidate Diesel test results are included in

Table 2.- Table 2. below, in both brake-specific and distance-specific formats.

Table 2.9 Comparison of control Diesel and hybrid emissions control technologies during the light combined vehicle weight emissions tests in Long Beach CA.

			THC	CH4	NMHC	NOx	NO	NO2	CO	CO2
			[g/mile]	[g/mile]	[g/mile]	[g/mile]	[g/mile]	[g/mile]	[g/mile]	[g/mile]
Regional Route 1	Segment 1 - Cold	Diesel	3.4011	0.5847	2.8657	109.3199	71.4017	0.1502	11.5805	27574.01
		Hybrid	0.0277	0.0065	0.0216	0.7559	0.3314	0.2567	0.6147	1011.36
		Difference	-99.2%	-98.9%	-99.2%	-99.3%	-99.5%	70.9%	-94.7%	-96.3%
	Segment 2 - Hot	Diesel	0.0067	0.0021	0.0047	0.2433	0.1592	0.0046	0.4867	1015.46
		Hybrid	0.0178	0.0038	0.0143	0.5044	0.2755	0.084	0.7489	1041.05
		Difference	165.7%	81.0%	204.3%	107.3%	73.1%	1726.1%	53.9%	2.5%
	Segment 2 - Warm	Diesel	0.0069	0.0024	0.0047	0.3681	0.237	0.011	0.3548	1035.07
		Hybrid	0.0212	0.0009	0.0199	0.9194	0.5496	0.0847	0.2962	794.19
		Difference	207.2%	-62.5%	323.4%	149.8%	131.9%	670.0%	-16.5%	-23.3%
			THC	CH4	NMHC	NOx	NO	NO2	CO	CO2
			[g/mile]	[g/mile]	[g/mile]	[g/mile]	[g/mile]	[g/mile]	[g/mile]	[g/mile]
Regional Route 2	Segment 1 - Cold	Diesel	0.1504	0.046	0.1082	2.1738	1.4109	0.0252	0.4978	1708.14
		Hybrid	0.0201	0.0038	0.0167	1.6542	0.561	0.8177	0.1752	833.26
		Difference	-86.6%	-91.7%	-84.6%	-23.9%	-60.2%	3144.8%	-64.8%	-51.2%
	Segment 2 - Hot	Diesel	0.0108	0.0057	0.0056	0.4579	0.3012	0.0071	0.4784	1076.74
		Hybrid	0.0062	0.0039	0.003	1.1737	0.5608	0.3215	0.536	829.19
		Difference	-42.6%	-31.6%	-46.4%	156.3%	86.2%	4428.2%	12.0%	-23.0%
	Segment 2 - Warm	Diesel	0.0274	0.001	0.0261	2.5345	1.6651	0.0207	0.4051	1486.28
		Hybrid	0.008	0.0047	0.0037	2.192	0.9534	0.7471	0.243	559.17
		Difference	-70.8%	370.0%	-85.8%	-13.5%	-42.7%	3509.2%	-40.0%	-62.4%

Table 2.10: Candidate Diesel-electric hybrid vehicle, light-weight configuration, A-2-Light, work-specific emissions rates over different test routes.

Test Routes		THC	CH4	NMHC	NOx	NO	NO2	CO	CO2
Regional Route 1		[g/bhp-hr]	[g/bhp-hr]	[g/bhp-hr]	[g/bhp-hr]	[g/bhp-hr]	[g/bhp-hr]	[g/bhp-hr]	[g/bhp-hr]
Segment 1	Cold	0.0118	0.0027	0.0092	0.3207	0.1406	0.1089	0.2608	429.13
Segment 2	Hot	0.0089	0.0019	0.0071	0.2504	0.1368	0.0417	0.3718	516.80
Segment 2	Warm	0.0133	0.0006	0.0125	0.5778	0.3454	0.0533	0.1861	499.06
Total		0.0110	0.0015	0.0095	0.3663	0.2185	0.0548	0.2853	498.71
Regional Route 2									
Segment 1	Cold	0.0091	0.0017	0.0076	0.7471	0.2534	0.3693	0.0791	376.35
Segment 2	Hot	0.0033	0.0021	0.0016	0.6225	0.2975	0.1705	0.2843	439.81
Segment 2	Warm	0.0039	0.0023	0.0018	1.0501	0.4567	0.3579	0.1164	267.88
Total		0.0040	0.0021	0.0023	0.6343	0.3053	0.2072	0.2485	419.16
Local Route									
Segment 1	Cold	0.0030	0.0019	0.0013	0.7947	0.3091	0.3283	0.3058	470.51
Segment 2	Hot	0.0047	0.0046	0.0010	0.6864	0.3450	0.1613	0.1996	490.80
Segment 2	Warm	0.0028	0.0023	0.0008	0.1540	0.0751	0.0404	0.1212	309.75
Total		0.0047	0.0033	0.0019	0.6491	0.3009	0.2296	0.2361	466.71

Table 2.4: Candidate Diesel-electric hybrid vehicle, light-weight configuration, A-2-Light, distance-specific emissions rates over different test routes.

Test Routes		THC	CH4	NMHC	NOx	NO	NO2	CO	CO2
Regional Route 1		[g/mile]	[g/mile]	[g/mile]	[g/mile]	[g/mile]	[g/mile]	[g/mile]	[g/mile]
Segment 1	Cold	0.0277	0.0065	0.0216	0.7559	0.3314	0.2567	0.6147	1011.36
Segment 2	Hot	0.0178	0.0038	0.0143	0.5044	0.2755	0.0840	0.7489	1041.05
Segment 2	Warm	0.0212	0.0009	0.0199	0.9194	0.5496	0.0847	0.2962	794.19
Total		0.0203	0.0028	0.0176	0.6801	0.1017	0.8021	0.5297	925.88
Regional Route 2									
Segment 1	Cold	0.0201	0.0038	0.0167	1.6542	0.5610	0.8177	0.1752	833.26
Segment 2	Hot	0.0062	0.0039	0.0030	1.1737	0.5608	0.3215	0.5360	829.19
Segment 2	Warm	0.0080	0.0047	0.0037	2.1920	0.9534	0.7471	0.2430	559.17
Total		0.0076	0.0040	0.0044	1.2252	0.4003	1.2366	0.4799	809.67
Local Route									
Segment 1	Cold	0.0067	0.0042	0.0030	1.7749	0.6904	0.7333	0.6831	1050.90
Segment 2	Hot	0.0101	0.0098	0.0021	1.4767	0.7423	0.3469	0.4294	1055.90
Segment 2	Warm	0.0060	0.0049	0.0016	0.3304	0.1611	0.0866	0.2601	664.58
Total		0.0103	0.0072	0.0042	1.4133	0.4999	1.7336	0.5141	1016.20

Table 2.5: Control Diesel vehicle, light-weight configuration, work-specific emissions rates over different test routes.

Test Routes		THC	CH4	NMHC	NOx	NO	NO2	CO	CO2
Regional Route 1		[g/bhp-hr]	[g/bhp-hr]	[g/bhp-hr]	[g/bhp-hr]	[g/bhp-hr]	[g/bhp-hr]	[g/bhp-hr]	[g/bhp-hr]
Segment 1	Cold	0.1418	0.0244	0.1194	4.5564	2.9760	0.0063	0.4827	1149.27
Segment 2	Hot	0.0034	0.0011	0.0024	0.1244	0.0814	0.0024	0.2489	519.17
Segment 2	Warm	0.0034	0.0012	0.0023	0.1832	0.1180	0.0055	0.1766	515.30
Total		0.0050	0.0014	0.0037	0.2038	0.1377	0.0039	0.2261	521.95
Regional Route 2									
Segment 1	Warm	0.0609	0.0186	0.0438	0.8804	0.5714	0.0102	0.2016	691.79
Segment 2	Hot	0.0051	0.0027	0.0026	0.2148	0.1413	0.0033	0.2244	505.11
Segment 2	Warm	0.0111	0.0004	0.0106	1.0271	0.6748	0.0084	0.1642	602.31
Total		0.0118	0.0043	0.0079	0.3340	0.2312	0.0045	0.2172	533.60
Local Route									
Segment 1	Cold								
Segment 2	Hot								
Segment 2	Warm								
Total									

Table 2.13: Control Diesel vehicle, light-weight configuration, distance-specific emissions rates over different test routes.

Test Routes		THC	CH4	NMHC	NOx	NO	NO2	CO	CO2
Regional Route 1		[g/mile]	[g/mile]	[g/mile]	[g/mile]	[g/mile]	[g/mile]	[g/mile]	[g/mile]
Segment 1	Cold	3.4011	0.5847	2.8657	109.3199	71.4017	0.1502	11.5805	27574.01
Segment 2	Hot	0.0067	0.0021	0.0047	0.2433	0.1592	0.0046	0.4867	1015.46
Segment 2	Warm	0.0069	0.0024	0.0047	0.3681	0.2370	0.0110	0.3548	1035.07
Total		0.0101	0.0029	0.0075	0.4159	0.0080	0.8031	0.4613	1065.15
Regional Route 2									
Segment 1	Warm	0.1504	0.0460	0.1082	2.1738	1.4109	0.0252	0.4978	1708.14
Segment 2	Hot	0.0108	0.0057	0.0056	0.4579	0.3012	0.0071	0.4784	1076.74
Segment 2	Warm	0.0274	0.0010	0.0261	2.5345	1.6651	0.0207	0.4051	1486.28
Total		0.0258	0.0093	0.0172	0.7310	0.0099	0.6637	0.4752	1167.78
Local Route									
Segment 1	Cold								
Segment 2	Hot								
Segment 2	Warm								
Total									

2.3.3 CONCLUSIONS FROM DEVELOPMENT (MORGANTOWN, WV) AND DEMONSTRATION TESTING (LONG BEACH, CA)

The purpose of this project was to accelerate deployment of zero and near zero emission cargo transport technologies that would target reductions in regulated exhaust emissions and greenhouse gases along goods movement corridors. To this end, Volvo Trucks developed and demonstrated plug-in hybrid electric drayage truck technology that additionally implemented geo-fencing, driver information, hybrid controls features and advanced exhaust aftertreatment temperature management user a post-turbo mini-burner. These combined technologies targeted very low NOx emissions levels when in nonzero emission operational modes.

During the developmental testing in Morgantown, WV, hybrid operation and mini-burner activation were tested separately using the same test platform capable of operating in diesel only, diesel with mini-burner, and diesel hybrid with mini-burner modes. The use of the mini-burner reduced route-averaged NOx emissions across all test routes and combined vehicle test weights by ~50%-90%, when compared to traditional diesel-only operation. This improvement was accompanied by mixed effects on already low levels of CO and THC emissions, and at an approximate fuel penalty (CO2 emissions) of 3%-6.5%.

When hybrid operation was combined with the mini-burner technology, CO2 emissions were reduced compared to both diesel-only and diesel with mini-burner, across all test routes and combined vehicle test weights. However, when hybrid operation was combined with the mini-burner technology, NOx emissions improvements were realized for light-load and cold-start conditions but were increased over traditional diesel only operation for higher load and warm operation. Hybrid operation with the mini-burner essentially reduced NOx emissions for only light load operation, as the additional thermal management challenges introduced by hybrid operation, particularly in already challenging transient mixed high- and low-load operation, adversely affected the conversion efficiency of the exhaust after-treatment system.

These trends were similarly reported during the demonstration phase of the program, during testing in the Port of Long Beach region. For this testing, diesel operation with mini-burner exhaust temperature control was not tested as an individual configuration. Rather, a modern diesel control vehicle was used as a benchmark for the plug-in hybrid technology with mini-burner and non-zero emission reduction technologies listed above. Tailpipe NOx emissions for the hybrid test vehicle were lower for the cold segment portions of testing and for lighter load operation. For hot test operation, when the vehicles had been operating immediately prior to the test commencement, and for higher load operation, the diesel control vehicle exhibited improved control of tailpipe NOx emissions.

Although not as pronounced as those results from the Morgantown PEMS testing, presumably due to further refinement of control strategies, the hybrid strategy control seemed to limit catalyst thermal management benefits that were anticipated from the mini-burner technology. The coupling of burner technology with the hybrid electric powertrain resulted in an overall GHG penalty.

2.4 FINDINGS FROM MINI-BURNER DEMONSTRATION

The Mini-burner is a promising exhaust heating technology, that could complement the conventional diesel powertrain (baseline) really well for GHG reduction, particularly in the light load and urban duty cycle application. However, the study points out that, when coupling burner technology with the hybrid electric powertrain, the

resulting penalty to the overall GHG from frequent hysteresis of SCR cool down/temperature drop arising from switch to electric mode overcomes the realized benefit of NOx reduction, thus provided by the burner. In urban duty cycle application, the low mass flow conditions make it further difficult to move the thermal energy provided by the burner, across the SCR brick, quick enough to achieve light-off and thereby high-NOx conversion. In certain real-world routes consisting of extended idle events, we observed the impact of burner on GHG to be high, particularly due to the engine actuator’s heat mode strategy to minimize fuel consumption.

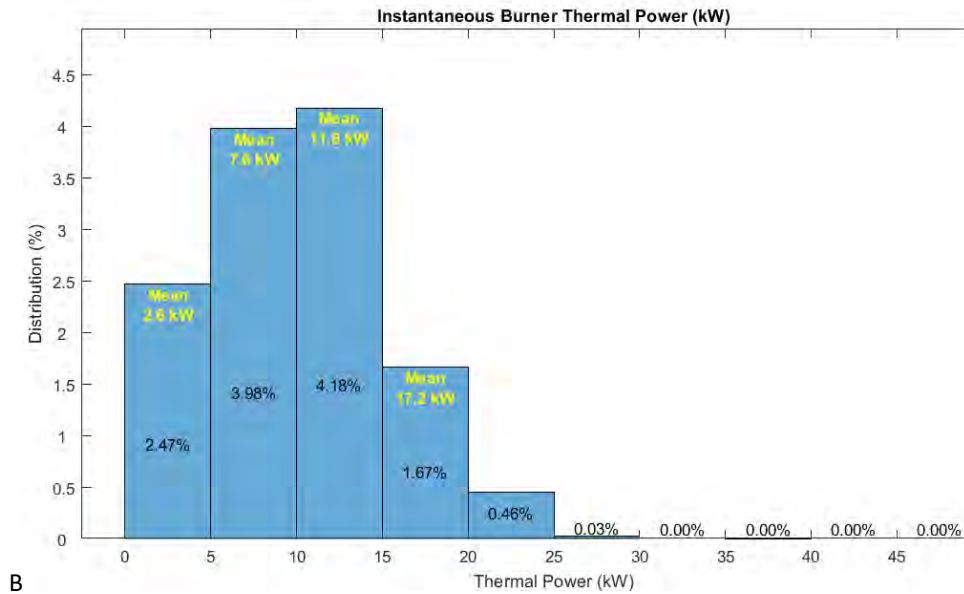

Figure 2.4.1 Observed thermal power demand as a function of total vehicle operation time.

Although, the burner was capable of achieving up to 50kW of instantaneous thermal power, the average thermal demand observed in real-world conditions was of the order of ~12kW (see Figure 2.4.1). The plot above shows the distribution of the thermal demand as a percentage of total vehicle operation time.

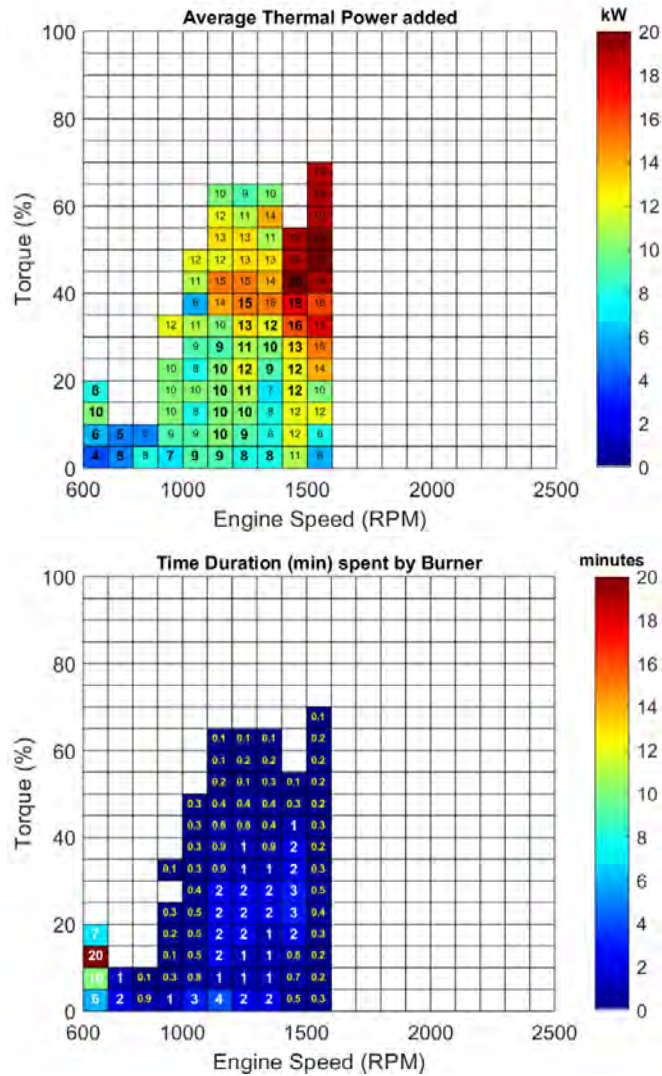

Figure 2.4.2 Micro-burner operational characteristics as a function of engine load and speed.

Figure 2.4.2 includes examples of the distribution of average thermal power added by the burner and the respective burner ON durations, across the different routes tested in hybrid electric powertrain mode. Also, as evident from the duration of heat up times, the burner technology offered the best flexibility for the ECU to control the transient thermal demand from the SCR, amongst the several other pathways considered to achieve exhaust heating.

3.0 PRIMARY COMPONENT #2 – POWERTRAIN SOFTWARE PHEV XECU

The XECU was added as an additional ECU on the Hybrid truck to create Electric Maps and automatically manage the Powertrain Mode (Electric vs Diesel) of the truck. XECU reads various CAN signals and logs them while the truck is in operation and processes all the data once the truck is stopped and keyed-off. The software generates Geofence Maps which define dynamically created Electric Zones so that the truck can use these maps on its next operation and enter Electric Mode automatically when it enters an Electric Zone, to conserve fuel and reduce Emissions.

Software that runs on XECU was developed to read/ write CAN signals, get GPS info from GPS modem and a few other functions. Software was designed with modular approach so that multiple functions could run simultaneously.

We developed our software so that one hardware (for example, CAN interface) can be used by multiple software applications running on same PC. We also used Encapsulation so that applications developed by external companies (for example, the Eco-Drive application which UCR developed) cannot send custom signals on CAN channels which can detriment the truck's performance or access proprietary data.

3.1 ELECTRIC GEOFENCE MAPS

Below are screenshots of the Electric Maps that the PHEV truck generated during operations around the Long Beach port area over time. As can be seen, the Maps grew with time as the truck was driven more and more. The green areas in the map represent the locations which are suitable for Electric Performance, and red denotes unsuitable locations. The truck will go into Electric Mode automatically whenever it enters a Green Zone and exits Electric Mode automatically when leaving a Green Zone or when the speed (for ex, 45 MPH) or power requirements (for ex, 1200KW) reach a predefined level. The Speed and Power limits were designed to optimize the performance of the battery.

The current parameters were set based on the constraints of PHEV #3 design – battery sizing and electric motor power. The top speed for ZE mode (45 MPH) and power requirements (1200kW) are a result of limited ability to operate in above those levels while in ZE mode. The amount of power required to travel greater than 45 MPH with a load would rapidly discharge the battery. A larger battery would potentially enable higher speed operation in ZE mode, for example. The wide range of engineering trade-offs could not be fully explored in this project.

This is just one application of the Electric Geofence Mapping potential, as it could also be designed to include disadvantaged community boundaries, residential areas, or high emissions areas such as Ports or warehouses. This technology has the potential to improve air quality in targeted areas by controlling when the PHEV enters and leaves zero-emission mode.

Map1 – initial map of Electric Zones generated by XECU (green = ZE zone)

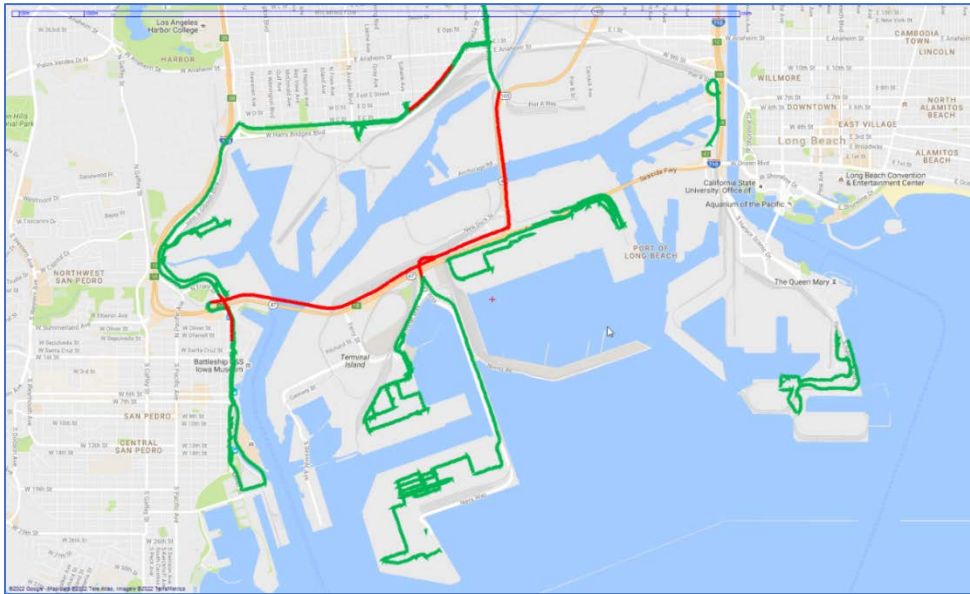

Map 1 shows the first ZE zones (Green lines) created by the system, with limited red (engine-on) zones

Map2 – second map of Electric Zones generated by XECU (green = ZE zone)

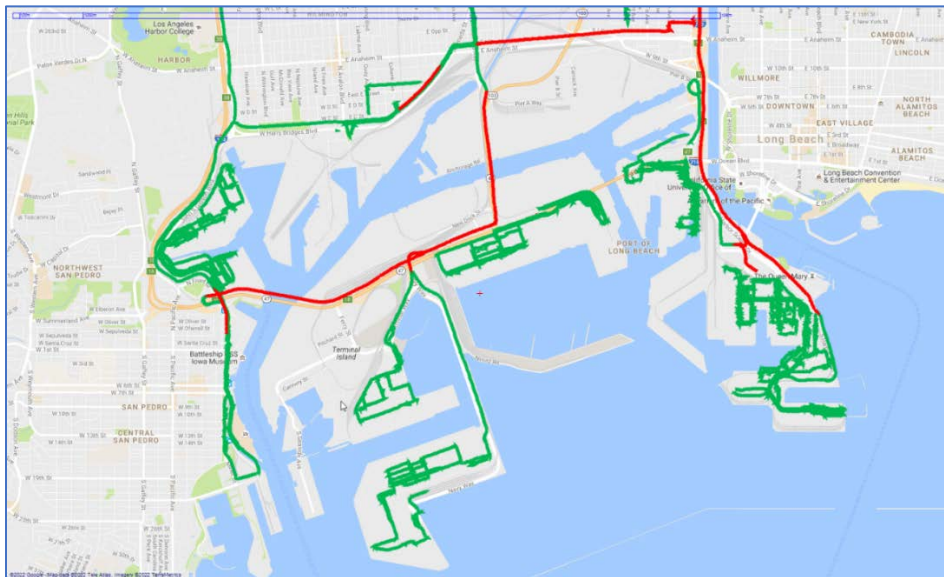

Map 2 shows that as more routes are driven, the zones (Green lines) expand, as does the red (engine-on) zones

Map3 – third map of Electric Zones generated by XECU (green = ZE zone)

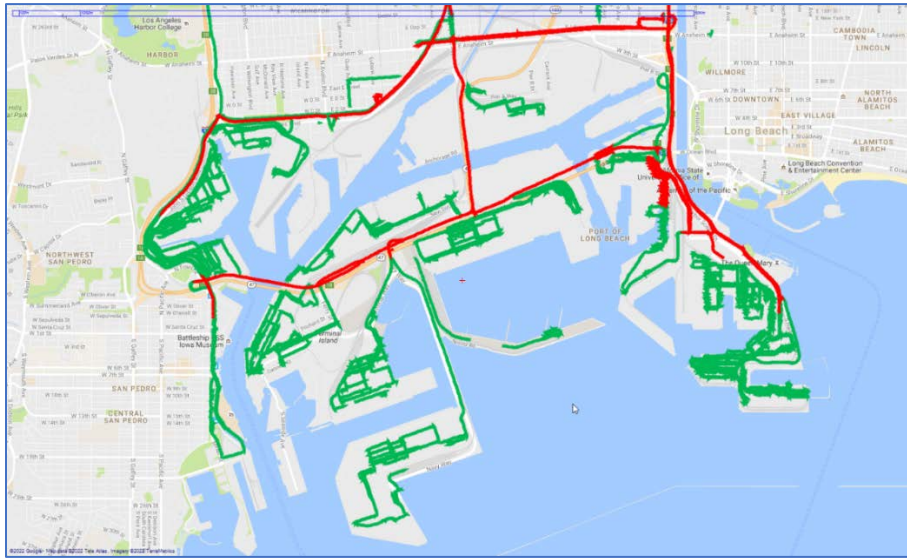

Map 3 shows additional development of the zones as truck operation continued

3.2 ISSUES FACED DURING DEVELOPMENT:

1. Cellular Signal

Multiple cellular modems from different companies were tried, but each one of them faced technical issues and were not very reliable, which could have affected the Eco-Drive application because the application is heavily reliant on Internet connectivity to get the traffic signal phase and timing (SPAT) info.

We tried different positions for the cellular antenna to achieve good signal reception, with different results for different trucks. We tried to place the antenna where there was minimal metal - for example first we placed the antenna near a window or the windshield. That strategy worked for one truck. For other trucks, we had to drill holes through the cab, run cables and mount antennas on the truck exterior. This did help where there was a strong cellular signal. For spots with poor cell signal, nothing we tried worked well, even having a cell signal booster inside the truck did not work in those areas. It appears this is simply the state of cellular coverage in and around the ports at the time of testing.

2. USB port connection

In the PHEV #1, a tablet was used to show the current truck location and geofence. CAN signals were read using an external device which was connected to the USB port of the tablet. This USB connection was not stable and disconnected frequently due to bumps on the road. So, for PHEV #2 and #3, USB connections were not used and were replaced by more stable DB9 connectors.

3. Radar Calibration

For the Eco Drive application, we used radar to show on the Display when there was a vehicle in front of the truck. The driver can take a decision on whether to maintain the recommended speed or slow down based on this information. One problem we faced during development was that the radar sensor needed to be calibrated, and it took multiple attempts to calibrate that sensor. Challenges we faced were:

- The conditions needed to be ideal for the calibration to be successful

- The failure messages were not user-friendly for understanding why calibration failed
- Hardware failure issues

We reported those issues to the relevant department and they will be used to improve the quality of next versions of our Radar Sensors.

3.3 CONCLUSIONS

We found that the XECU provided several important benefits based on our design decisions and demonstration learning. Those learnings will be applied in future products:

- 1) Modularity
- 2) Encapsulation
- 3) Self-generating electric zone geofencing

The project allowed several continuous improvements to the XECU software from the first truck to the latest version used in the third truck, based on our previous learnings. We created multiple system layers, including the platform layer and micro services layer which facilitated duplex communication between platform layer and application layer.

The first Hybrid truck had static Geofences (no self-learning). Electric Mode zones were defined for the Long Beach port area, as the port was identified as a geographic area that needed reduced emissions. Based on the static geofence, the truck would go to Electric Mode whenever it entered the port area. For the second and third trucks, a goal was to improve the static geofences and the project developed the idea of dynamic geofences so that the truck can make and use Electric Mode zones where ever it is driven.

An area not considered at project initiation, which has now become important to many agencies and emission control programs is addressing disadvantaged communities (DACs). In this project, the dynamic mapping system design did not take those community boundaries into account, which meant the system could set a red area (unsuitable for Electric operation) within a DAC – where electric operation would actually be preferred. Using the techniques of the earlier truck design, it is possible to include those boundaries in future versions of the software as static geofences. Locations defined as zero-emissions for external reasons such as Environmental Justice, can be automatically set to green for Electric Mode.

Another benefit from this work that will be taken forward is software control of electric air compressors. The trucks were designed to have an eAir Compressor which builds air pressure in the tank when the truck is in Electric Mode. The traditional system uses a belt-driven pump connected to the diesel engine. The ULTRA project was able to help other project teams which were working on electric trucks with the work of programming their eAir compressors. Fully electric trucks require eAir compressors, and hybrid trucks benefit from the reduction in engine load by removing the belt-driven compressor, enabling slightly lower fuel use and emissions.

4.0 PRIMARY COMPONENT #3: ECO-DRIVE

4.1 BACKGROUND

As part of the Ultra project, the project team developed a C-ITS application, called *Eco-Drive*, that uses signal phase and timing information from the upcoming traffic signal along with information about the state of the host vehicle and surrounding traffic to recommend driving speed for passing through the intersection in an energy-efficient manner. We also conducted an extensive simulation-based evaluation to estimate the energy savings and emission reductions potential of Eco-Drive under a variety of conditions. Lastly, we deployed Eco-Drive on PHEV #3 and collected data to evaluate its efficacy in real-world settings. Key findings and lessons learned from our efforts in this project are summarized below.

4.2 ECO-DRIVE DEVELOPMENT AND DEMONSTRATION

The development of Eco-Drive was a collaborative effort between Volvo and UCR, drawing on the strength and skill set of each party. Volvo provided a conventional diesel truck for use during the development. The truck came equipped with necessary hardware including on-board computer, radar sensor, GPS receiver, communication modem, display, and other accessories. UCR designed the system architecture, developed algorithms, and implemented them into software. Volvo engineers and UCR researchers then worked together on the integration of the hardware and software and the implementation of the system onto the truck. The team also made significant efforts in designing and refining the user interface of Eco-Drive, with inputs from truck drivers.



User interface of Eco-Drive indicating status of traffic signal, recommended range of driving speed, presence of preceding vehicle, and road speed limit

In parallel with the Ultra project, UCR worked with local transportation agencies and their technology vendors to create a connected vehicle testbed in Carson, CA, as part of the CEC-funded Eco-FRATIS project. The testbed consists of 15 connected intersections across three arterial freight corridors that carry truck traffic to and from the San Pedro port complex. In addition, with support from the partners on both projects, Volvo and UCR organized an event in Carson on March 6, 2019, to demonstrate the Eco-Drive technology to project sponsors and key stakeholders. The demo event was attended by more than 80 attendees who were able to experience Eco-Drive first hand on two of the connected corridors.

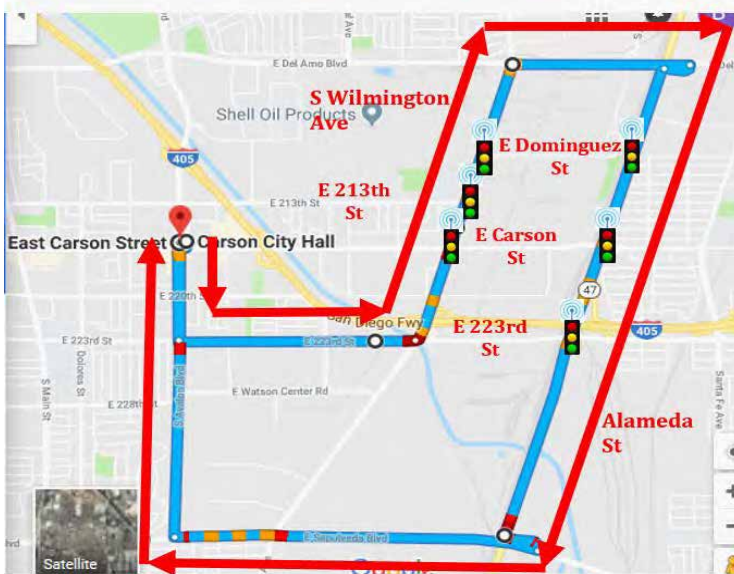

Demonstration of Eco-Drive in Carson on March 6, 2019

4.3 ECO-DRIVE DEPLOYMENT ON PHEV

As part of the PHEV demonstration, Eco-Drive was installed on PHEV #3 and data were collected from the truck while it was operated by IBT. During the demonstration, there were periods when Eco-Drive was not working due to poor cellular connectivity or issues with the server. Therefore, the project team treated the data from these periods as baseline data and compared them with the data from when Eco-Drive was working. The results from the Eco-Drive performance evaluation on PHEV #3 show that driving with Eco-Drive resulted in less energy consumption than driving without it by 2% to 10%, but the underlying reasons for which the energy savings were achieved varied by roadway segment. In both directions of Alameda St between 223rd St and Dominguez St, Eco-Drive helped cut down the number of stops at connected intersections considerably, which resulted in less acceleration and deceleration and contributed to energy savings. Note that the energy savings observed in both directions of the roadway segment between 223rd St and Dominguez St (9.7% for northbound and 10.4% for southbound, respectively) are much higher than the energy savings in both directions of the roadway segment between 223rd St and Carson St (1.9% for northbound and 3% for southbound, respectively). This may be because the driver was able to use Eco-Drive at three of the four intersections between 223rd St and Dominguez St, while he could do so at only two of the three intersections between 223rd St and Carson St.

On all four roadway segments, the unconnected intersection with Ramp 405W is located in the middle of the segments. This leads to a discontinuity in Eco-Drive's ability to recommend an energy-efficient driving speed profile

through the segments, which plays a major role in the resulting energy savings. It is expected that if the intersection with Ramp 405W is also connected, the performance of Eco-Drive in terms of energy savings will be greater.

4.4 ECO-DRIVE SIMULATION-BASED EVALUATION

Histograms of acceleration rate of the simulated truck along Alameda St Northbound without and with Eco-Drive

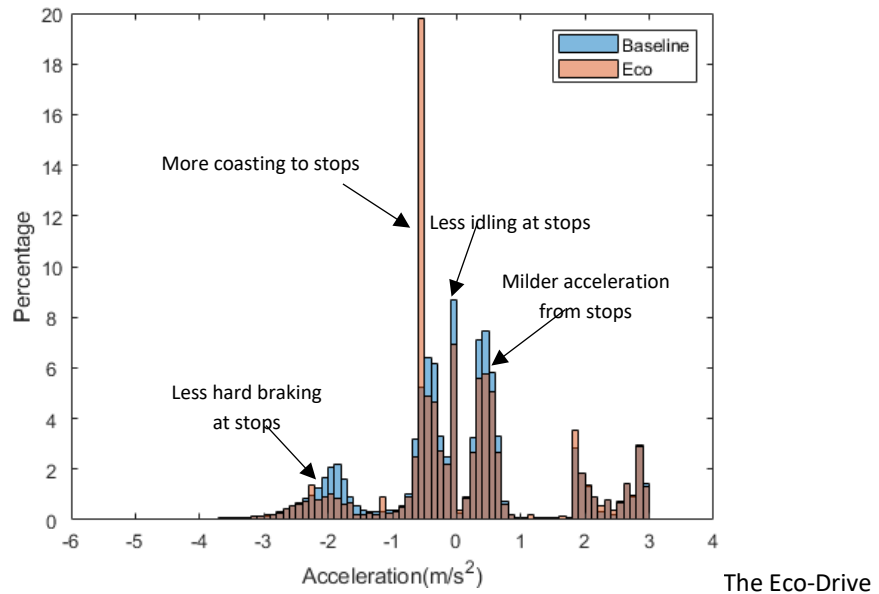

The Eco-Drive evaluation using data collected from PHEV #3 is based on a limited amount of data. Also, the vehicle, traffic, and environmental conditions during the baseline and Eco-Drive data collection periods may not be the same. Therefore, the project team also conducted the performance evaluation of Eco-Drive on two connected corridors—Alameda St and Wilmington Ave—in a bi-directional traffic simulation environment. The evaluation results show that Eco-Drive helps the host vehicle achieve significant energy savings and emission reductions as a result of having fewer number of stops and milder acceleration and deceleration. Overall, Eco-Drive helped achieve energy savings by 6% to 18% and reduce NOx emission by 3% to 5%.

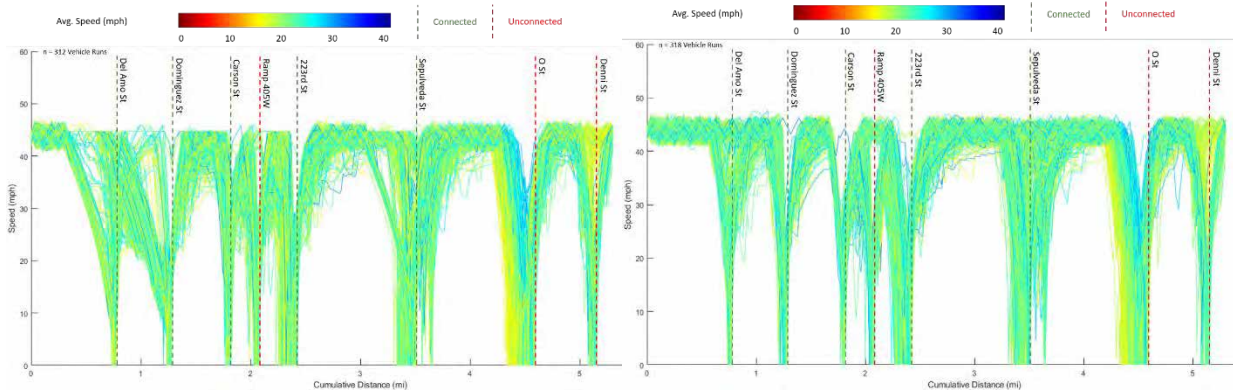

Speed profiles of the simulated truck along Alameda St Southbound without Eco-Drive (left) and with Eco-Drive (right); each figure showing speed profiles from 350 simulation runs

The results also show that the energy savings and emission reduction benefits vary by roadway segment. For the segments with long intersection spacing, Eco-Drive can provide energy savings without sacrificing travel time. On

the other hand, for the segments whose intersection spacing is not long enough for the host vehicle to reach the cruising speed after passing through one intersection before it starts to adjust the speed in preparation for the next intersection, Eco-Drive can provide even more energy savings, but at the expense of longer travel time.

4.5 CONCLUSIONS

Eco-Drive was shown, through a rigorous simulation modeling, to help the host vehicle consume less energy by 6% to 18% when traveling on arterial freight corridors with connected intersections. The energy metric used in the Eco-Drive evaluation represents the energy needed to provide the required tractive power at the wheels. Therefore, the level of energy savings that can be achieved by Eco-Drive would be similar for conventional trucks and PHEV trucks. In addition, Eco-Drive was found to help reduce tailpipe NOx emissions by 3% to 5%. This NOx emission result is based on a modeling of conventional trucks. The impact of Eco-Drive on NOx emission from PHEV trucks is expected to be minimal as tailpipe NOx emissions from PHEV trucks are already very low.

A widespread adoption of Eco-Drive would likely bring significant energy saving and emission reduction benefits. However, the effectiveness of Eco-Drive at reducing vehicle energy consumption and emissions could vary by a number of factors, such as corridor characteristics (number of signalized intersections, intersection spacing, how many of the intersections are connected, terrain, etc.), vehicle characteristics (body type, weight, etc.), traffic characteristics (congestion level, signal timing plan, etc.), among others. With many factors at play, it is challenging to generalize its benefits. More research will be needed to characterize the level of energy savings and emissions reduction that Eco-Drive could provide under a variety of settings. Similarly, the potential benefits to a battery-electric vehicle (BEV) from utilizing Eco-Drive would be higher efficiency (miles/kWh) resulting in extended range for a given storage capacity (kWh). These factors are topics for future studies. This information will be useful for prioritizing the investment in connected infrastructure that is needed to enable Eco-Drive and other C-ITS applications.

The development, demonstration, and deployment of Eco-Drive was successful, and contributed to the overall goal of the Ultra project in advancing technologies that reduce greenhouse gas emissions, strengthen the economy, and improve public health and the environment—particularly in disadvantaged communities. Eco-Drive, with participation and contribution from over 15 public agencies and private entities, is also a great example of a collaborative effort to accelerate the demonstration and deployment of transportation technologies in California through public-private partnerships. These partnerships will be necessary to the promotion and wide-scale adoption of Eco-Drive and other C-ITS technologies in the future.

5.0 PRIMARY COMPONENT #4: DEPLOY 2 BEV TRACTORS

5.1 INTRODUCTION

Producers Dairy is a privately-owned dairy supplier and distributor based in Fresno, California. Established in 1932, they have a long legacy of providing California families with the highest-quality and freshest dairy products. They are not only a critical pillar in the food industry but also a veteran at adapting to societal changes. Producers is taking a proactive approach to meeting upcoming regulations such as the Advanced Clean Fleets rule, working for some time on plans to replace their diesel truck fleet with a fleet of fully electric trucks.

Producers Dairy is domiciled and largely operating in an AB 617 community. With a fleet of over 80 tractors travelling both short- and long-range routes throughout the state, they are an ideal candidate for this case study on electric truck adoption. Producers Dairy is committed to electromobility with plans in place to acquire many more EVs.

For this project, Producers Dairy acquired two Volvo VNR electric Class 8 tractors, to be deployed in their revenue operations fleet. Charging Infrastructure for the trucks was also designed and installed.

5.2 CURRENT OPERATIONS

The operations involved in the delivery process can be categorized into three phases — Pre-Delivery, Delivery, and Post-Delivery. The process begins when a customer places an order and concludes when the empty trailer is returned to the facility. This process is not linear, as many unexpected circumstances can disrupt the flow, requiring flexibility to accommodate these changes. Delivery and fleet operations serve as a backdrop to the delivery-oriented operations. Driver supervisors, fleet managers, and maintenance technicians continuously work to optimize efficiency and close gaps in the workflow.

Producers Dairy uses a variety of equipment to deliver to local stores, schools, warehouses, and big box retailers. For this project, Volvo Group focused on deliveries to warehouses and big box retailers as they utilize Class 8 tractors, commonly known as “big rigs”. Some orders fill an entire trailer, while others are a partial load and are therefore combined with other orders to maximize trailer space.

Producers Dairy Operations Overview

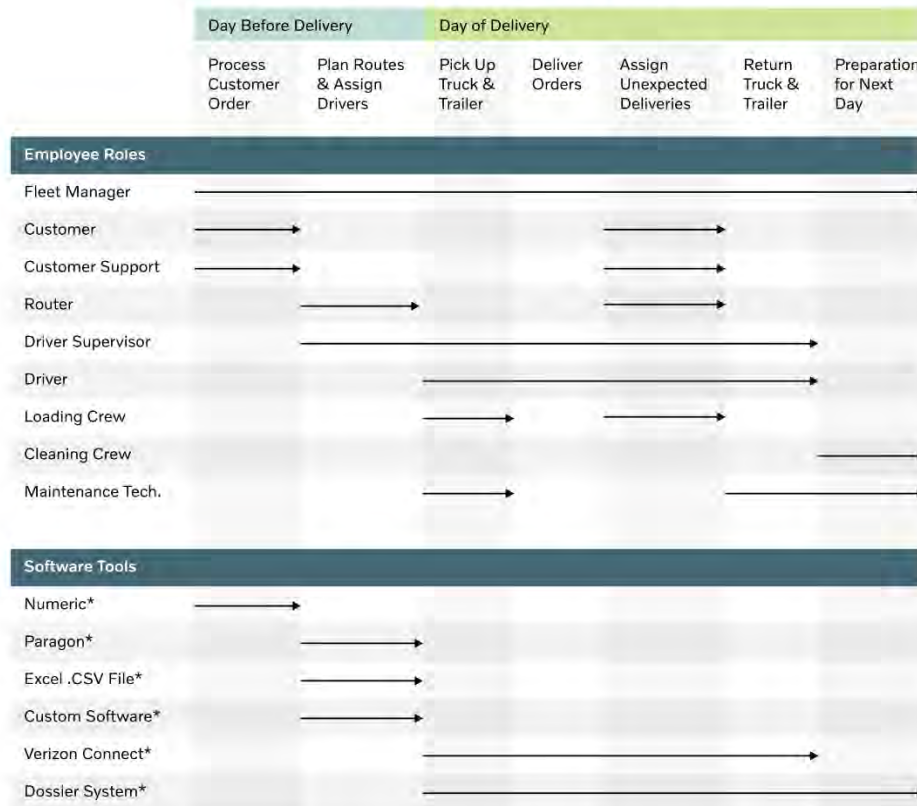

Operations Overview. Employee and software tools touchpoint at various points of operations, creating a dynamic environment.

5.2.1 PREPARING THE DELIVERY

An order from a Producers Dairy customer begins with the customer service team entering the order details into the CRM (Customer Relationship Management) system called Numeric. Each day, the routing team exports the list of delivery requests from Numeric into an Excel .CSV file. The file is imported into the routing software, Paragon, to create the initial routing schedule. Paragon takes into consideration the customer’s delivery window when creating the routing schedule. The routing team maintains close contact with customers, updating these parameters when needed to ensure routes are coordinated to match loading dock access and delivery window times.

Some delivery locations have facilities, such as a roll-up door or a lift gate, that require specific equipment. This is not a factor in the tractor (BEV or Diesel) but impacts the type of trailer used. Paragon is not able to consider these measures during routing. As a result, the router manually assigns drivers and trailers to each delivery route. The routing team tries to consistently assign drivers to the same routes to build the driver-customer relationship while also respecting driver seniority and route preferences. The finalized delivery schedule, or “hook up sheet”, is sent to driver supervisors the day prior. Custom software is used to import the finalized schedule from the Excel .CSV file into Verizon Connect, which displays route information and tracks delivery progress.

When the driver supervisors receive the “hook up sheet,” they call contract drivers to fill in any unassigned routes, ensuring all deliveries will be made. Contract drivers are not on the Producers Dairy payroll, typically have their own tractor, and are used when all Producers trucks are booked or drivers are not available to fill the required deliveries on a particular day. After the routes are divided up amongst the supervisors, the administrative assistant prints out copies of each driver’s route to be picked up the next day.

5.2.2 DELIVERY

Drivers are notified via text message the night before of their routes and reporting time for the following day. At the start of the day, drivers pick up a “handheld” phone as well as a paper route plan. The handhelds have Verizon Connect installed to show route information, track delivery progress, and alert supervisors when drivers deviate significantly from routes. Drivers select a truck of their choice then conduct a pre-trip inspection using a mobile application. The trailer is picked up at a separate site located approximately 0.25 miles away. The driver confirms the contents of the trailer before starting their delivery routes.

After all deliveries are completed, the trailer is dropped off to be cleaned and restaged for the next delivery. Drivers conduct a post-trip truck inspection, notating areas that need to be examined by maintenance technicians. Lastly, they return their handheld to the office before going home. A new process will be added for BEVs, including the proper parking of the tractor at the charging islands, and plugging in the tractor. Primary charging will be done overnight at the main facility, as there are currently very few options for on-route charging and as a result route planning will not be designed for on-route opportunity charging.

At the trailer yard, the cleaning crew empties and cleans trailers as they are dropped off. Packaging and crates are returned to stock to be reused. After cleaning, the trailer will be restaged for the next delivery.

5.2.3 DELIVERY OPERATIONS

When drivers encounter changes, problems, or exceptions on their routes, they contact their supervisor who will decide how the company responds. To ensure customers are satisfied, new routes are manually added to another driver’s schedule.

5.3 OVERALL FLEET OPERATIONS

The fleet manager looks for general efficiencies and opportunities to optimize overall operations and sets the tone for company culture.

5.3.1 MAINTENANCE TECHNICIANS

At the company’s main center, maintenance technicians use a six-bay facility for work that does not require a truck lift or pit. As electric trucks are added into the fleet, one bay will be dedicated for EV maintenance.

For major repairs and to reserve surge capacity, Producers Dairy technicians outsource approximately 25% of their work to dealers and third-party vendors. Towing and remote roadside assistance anywhere in California is also addressed by vendor partnerships.

The two BEVs in this project are covered by a Volvo Gold Maintenance contract, which requires the dealership (Affinity Trucks in Fresno) conduct all maintenance on a pre-paid basis. Producers has signed up for 72 months or 300,000 miles of Volvo Gold coverage to ensure the BEVs are well maintained while the Producers technicians receive training in BEV maintenance.

5.3.2 CHARGING INFRASTRUCTURE

Volvo Group partnered with AMPLY Power to provide the charging infrastructure for this project. Both parties closely collaborated with Producers Dairy and PG&E to determine the appropriate charging station requirements.

The grant awarded by the California Air Resources Board (CARB) South Coast requested deployment of charging infrastructure and electric trucks for Producers Dairy by November 2021. However, chip shortages extended procurement estimates for the 200 kW chargers from 5 weeks to 3 months. As a temporary solution to meet the delivery deadline, Producers Dairy opted for a portable charger that did not require significant infrastructure changes while awaiting the delivery of the larger permanent chargers. In addition to the increased procurement due to supply chain delays, all stakeholders experienced a steep learning curve during deployment process.

The City of Fresno took several months to issue a construction permit, which added to the delays faced by the project and pushed construction start to very near the limit of allowed timing.

5.4 COORDINATION AND COMMUNICATION WITH STAKEHOLDERS

Planning and installing the charging infrastructure was a collaborative effort between Volvo Group, PG&E, and Producers Dairy. Producers Dairy's position in this project was unique — acting as both a utility customer and a project partner. They had to strike a balance between being proactive in meeting business needs while remaining realistic to infrastructure performance. Likewise, Volvo Group and PG&E each had goals for the charging infrastructure. Volvo Group was concerned about charger installation and power output whereas PG&E focused on infrastructure longevity to withstand increased power usage over the next 10 years. Lack of coordination and transparent communication between the three parties resulted in misunderstandings of what was feasible.

Takeaways

- Stakeholder motivations and project expectations need to be aligned early in the process to avoid confusion later.
- It is important to quickly define roles and timelines with clear delineation of duties between the OEM, customer, utility company, and charger management stakeholders.
- The customer's fleet electrification goals should be taken into consideration when designing the initial charging infrastructure to ensure that it is sustainable and suitable for their long-term vision.
- Transparent communication between the customer, utility provider, and OEM is necessary to keep stakeholders informed on decisions and ensure they do not incur any negative impact.
- It is difficult for customers to do their own research and become subject matter experts in this area. OEMs should provide additional support to help customers navigate this new space.

5.5 FUTURE PROOFING

Plans for infrastructure upgrades must anticipate near and long-term needs. This can be challenging when battery technology, electric vehicle capacities, and charging speeds are quickly improving. Future proofing efforts should focus on infrastructure components that are resilient to these changes such as larger conduits to run more wires, larger pads for more transformers, and standardized mounting pads to switch in larger capacity chargers in the future. Absolute futureproofing is impossible but planning ahead during the initial infrastructure build can allow for flexibility in future upgrades. The Utility involved also has to consider fleet future proofing plans, so they can

ensure there is sufficient power as the customer implements future upgrades. PG&E, for example, asks for multi-year deployment plans in their EV Fleet agreements.

Takeaways

- Contrary to common beliefs, futureproofing involves more than charging capacity and speeds.
- The best approach to building robust infrastructure is to design the initial build with future growth in mind.

5.6 UNDERSTANDING CUSTOMER OPERATIONS

Diesel truck performance is largely determined by the engine, whereas for electric trucks it is contingent on its battery life. Factors that were previously trivial, such as route distance and load weight, now hold considerable impact in the EV context. In a dynamic operational environment, like Producers Dairy, unexpected usage such as additional deliveries and route deviations are common which can further disrupt efficiency. Understanding customer operations allows OEMs to address inefficiencies before they arise.

It is equally important for the OEM and customer to set realistic expectations on what is achievable. Producers Dairy had a vision for how they wanted EV trucks to operate around their chargers. However, as new information was gathered such as how towing trailers, minimizing reversing, and increasing cable costs further from the power source affected the performance of the infrastructure, three revisions were made to the initial plan. To streamline this process, it is crucial for OEMs to have conversations early in the project to not only understand the customer's long-term visions but also to set realistic expectations of what is achievable.

Takeaways

- To be set up for EV adoption success, OEMs and the customer need to engage in conversations early to understand in-depth how customers will use their trucks to identify areas of inefficiency.
- Understanding the customer's long-term visions will help set realistic expectations of what is achievable.

5.7 MANAGING EXPERTISE AND CONTROL

Since electromobility is still a rather new domain, there is limited research and resources for customers. When Producers Dairy began collaborating with Volvo Group to deploy EV trucks within their operations, the key decision maker did not have sufficient electromobility expertise to make informed decisions. To better navigate this situation in the future, OEMs may want to create a division that is dedicated to supporting the adoption, implementation and optimization of the EV trucks and will work in close collaboration with the customer, who will need a dedicated expert for this EV conversion. Because the current range limitations of an electric truck require considerable adjustments to customer's operations, OEMs will need a comprehensive understanding of customer operations — from truck- and delivery-specific details such as facilities, routes, load weights, stops, pickups, equipment power capacity, and utility access to details about the broader company culture like driver compensation, and even union contracts. The OEM and utility provider should also be included in all discussions to ensure both the charging infrastructure as well as EV trucks are correctly positioned for maximum performance and value. For example, the charging infrastructure should not be located far away from the utility point of connection. Ultimately the OEM should plan to support the customer and help them make informed decisions.

Takeaways

- Most customers are not knowledgeable about electromobility. As EV technology is rapidly changing, it is also becoming more difficult for customers to remain up to date on subject matter knowledge.
- As subject matter experts, OEMs should plan to support the customer and help them make informed decisions.

5.8 EXISTING SOFTWARE OVERVIEW

Producers Dairy uses several software packages to coordinate and track their business activities. These vary across their five brands, but this project focuses on those at the main Producers Dairy brand deliveries out of their Fresno, CA processing facility.

5.8.1 NUMERIC

Numeric is the Customer Relationship Management (CRM) software used to track customer information, orders, invoicing, and payments. It is used by their customer service team, management, and by the routing team to implement the orders scheduled for the following day. Once the routing for the next day is completed, planned deliveries are imported back into Numeric as a record of fulfillment.

5.8.2 PARAGON

Paragon routing software is used to plan the specific delivery routes for the next day based on the order list imported from Numeric. It optimizes the routes for efficiency in an automated way. The routing team and management are the only ones who interface with this software directly, keeping delivery windows and basic information for customers up to date as needed, and generating the following day's delivery schedule. The routing team uses this output to then assign drivers and trailers by hand, forwarding the resulting load board and delivery routes to appropriate managers for implementation the next day.

5.8.3 CUSTOM SOFTWARE

Producers Dairy uses a custom software package they commissioned to prepare routing information from the routing team and import each day's delivery schedule into the Verizon Connect software platform.

5.8.4 VERIZON CONNECT

The Verizon Connect software package receives the planned route information imported by the custom software, distributing this on handheld (cell phone) devices to each assigned driver, and tracks the route progress through telematics data on each truck. Management receives alerts from this software (for significant route deviations, for example), and can generate a variety of reports, for example of actual vs. expected route distances and timing.

5.8.5 DOSSIER

Dossier software is used to track and plan maintenance and repairs for vehicles at Producers Dairy. This helps to balance necessary repairs and preventive maintenance. Drivers enter their pre- and post-trip inspection reports into this software, and the maintenance crew use this software to plan each day's activities for their team.

Producers Dairy Data Flow

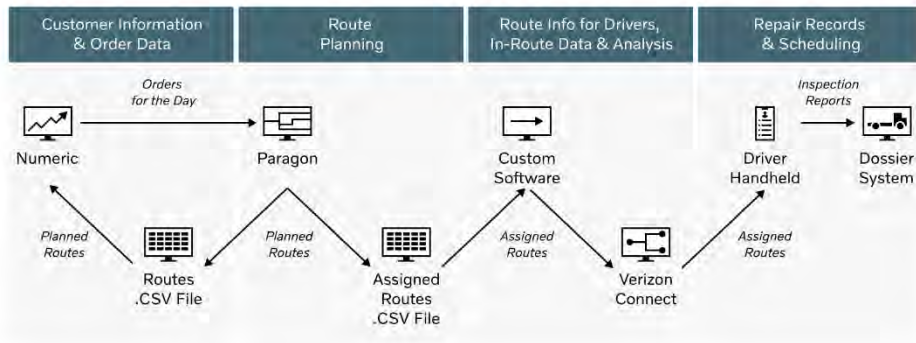

Data Flow. Information flows across various systems and software tools for different teams to use.

5.9 EV SPECIFIC SOFTWARE APPLICATIONS

AMPLY Power and GeoTab collaborated to provide a charging management solution to Producers Dairy. GeoTab was responsible for contributing the data integration for AMPLY’s software tool.

5.9.1 OBJECTIVES AND REQUIREMENTS

The complete charging infrastructure Producers Dairy has planned includes two permanent chargers as well as two portable chargers. The goal from a charge management perspective is to precisely couple the charger controls with planned and actual operations. The nature of Producers Dairy’s operations requires just-in-time planning, therefore the vehicle information retrieved from Paragon needs to be accurately displayed and continuously updated. In addition, Paragon routes are specific to trailers but the data integration is tied to the tractor. A new endeavor for AMPLY Power is to find a solution to connect tractors to their trailers. This will require some trial-and-error to create these mappings.

5.9.2 SOFTWARE FEATURES

AMPLY Power spearheaded the charge management software efforts for this project. Their OMEGA™ Charge Management System was used as a baseline for development. Features of the OMEGA™ System include power values, charging data, and fault information. However, Producers Dairy was unique in that their operations required the ability to act based on unforeseen circumstances. As a result, additional features, such as on-route monitoring as well as route optimization, were implemented to precisely monitor the state of the entire ecosystem. In addition, a dashboard was added to provide fleet managers a unified view of charger and vehicle usage. With this project, AMPLY Power has built strong integrations with Paragon, Verizon Connect, and Volvo Group APIs. Future considerations for this software include integrating trailer with tractor data as well as understanding driving range and battery estimation accuracy.

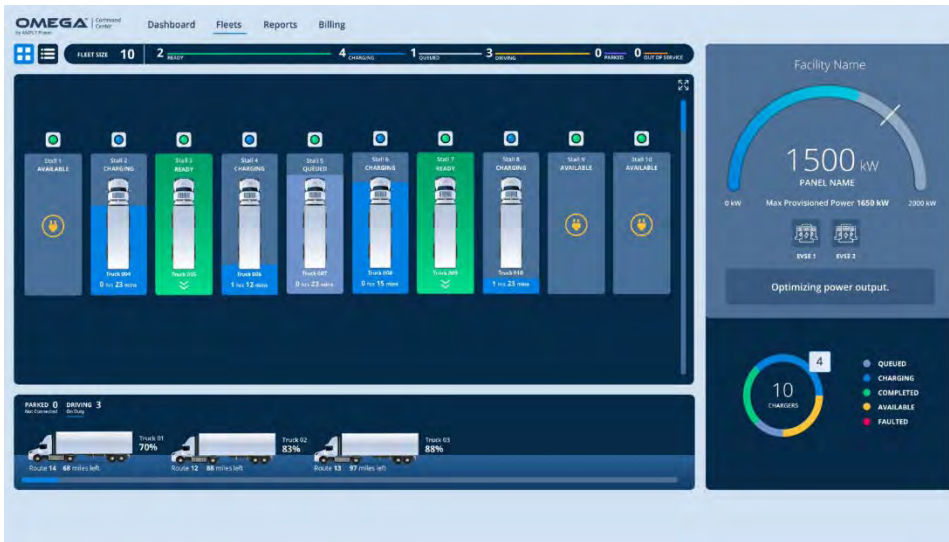

Dashboard. The dashboard provides a consolidated view of the ecosystem.

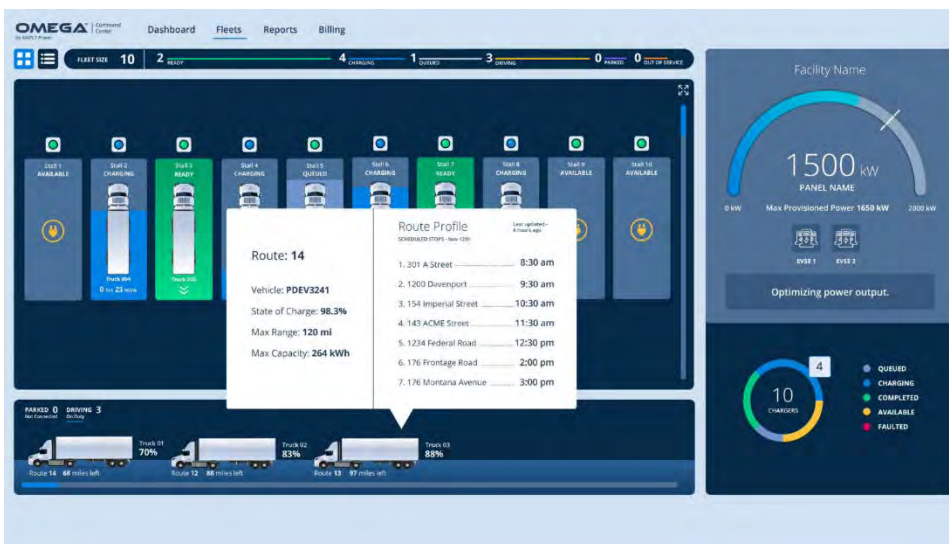

Dashboard. A pop-up shows detailed information on the moving vehicle such as vehicle state and route schedule.

Producers Dairy EV Data Flow

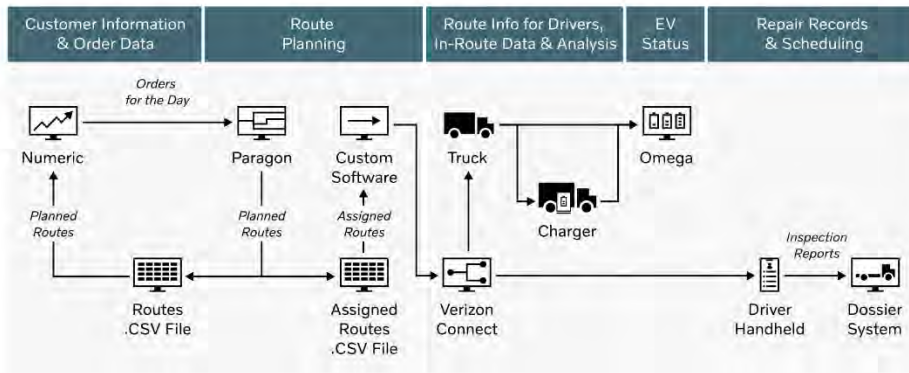

EV Data Flow. The addition of the OMEGA software allows for truck and charger status to always remain connected and visible.

5.10 DATA OVERVIEW

Since September 2021, telematics data from Producers Dairy’s trucks have been continuously collected and analyzed with the goal of providing a quantitative understanding of the impact of electric vehicle adoption on current operations.

The domains of interest were daily average distances driven and electric vehicle acceptable routes (below 100 miles). Understanding the daily average distances driven provided a comprehensive depiction of Producers Dairy’s delivery landscape. Likewise, identifying electric vehicle acceptable routes projected the magnitude of EV impact.

By default, the trucks send basic information such as GPS location, odometer reading, and fuel levels once every hour. The same data inputs are being analyzed in both diesel and electric conditions, with fuel level being substituted with state of charge. The frequency of truck data was too sparse for meaningful analysis; therefore, it was increased from once every hour to once every five minutes.

5.10.1 METHODOLOGY

The role of data in this project is two-fold - to be able to quantify the changes experienced during electric truck adoption and consequently provide recommendations to optimize routing for electric vehicles. As the electric trucks were continuously delayed, a Pre-Posttest analysis approach was selected to ensure that analytics quality was not affected. In this design, fleet operations will be assessed before and, then again, after the introduction of electric vehicles to measure its impact.

Given that the trucks will be travelling similar delivery routes, truck usage is anticipated to remain the same among diesel and electric trucks. However, the electric truck’s 100-mile range may skew certain aspects of data that will need to be adjusted for.

5.10.2 ANALYSIS AND RESULTS

The pre-test data sample focused on over 30 vehicles based out of Producers Dairy’s Fresno, California warehouse. Over the two-month period from November to December 2021, over 370,000 location messages were analyzed, on both daily and monthly scales, to generate heat map representations of delivery routes. The analytics focused on two main metrics - daily average distances driven and EV acceptable routes. Routes were defined as the group of deliveries involving one trailer. Analysis of these data points revealed the following trends and patterns.

Summary of Initial Findings

- Routes driven on Sunday were significantly lower in distance compared to other days. Contrastingly, Saturday and Friday were the days with the most distance travelled.
- Approximately 28.1% of Producers Dairy’s routes are electric vehicle eligible (below 100 miles)
- On average, each tractor will make two routes per day. Each route is typically with a different trailer.

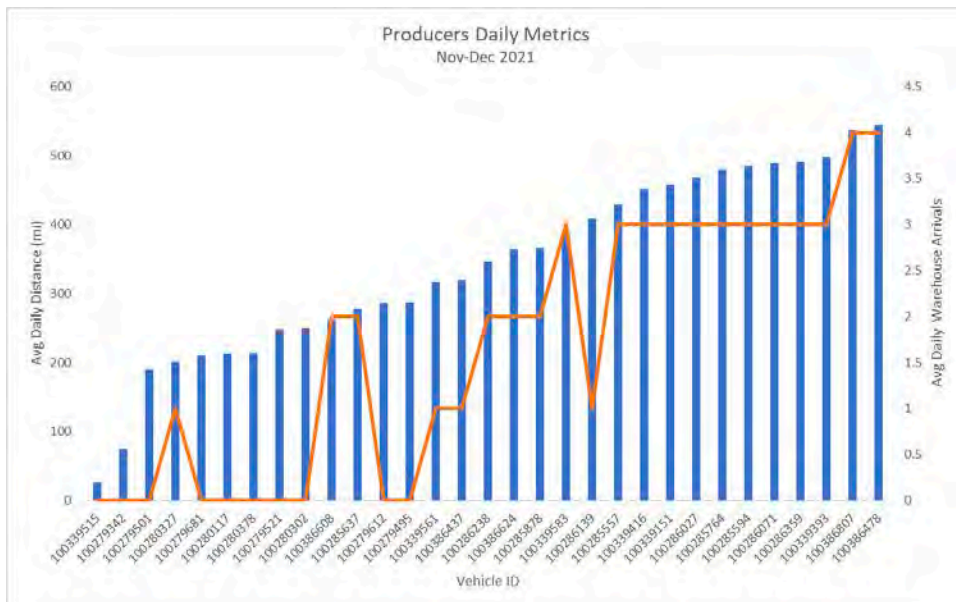

Daily Routes Driven. This graph compares average daily distances travelled to daily warehouse arrivals by vehicle.

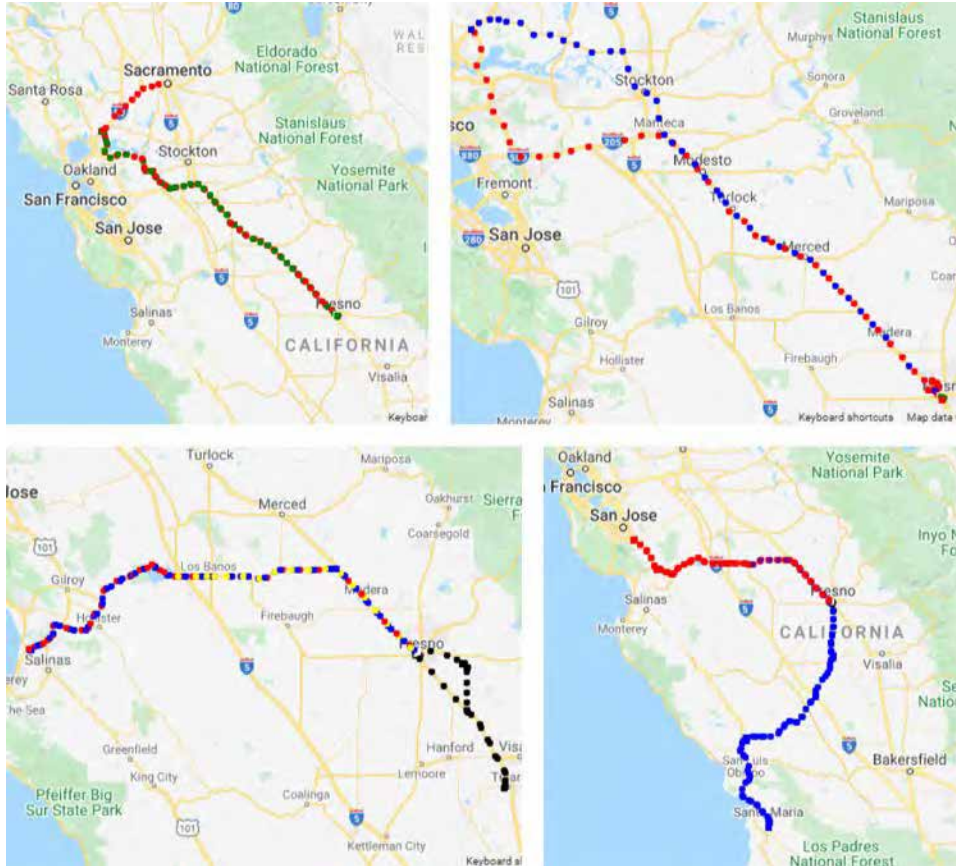

Route Heat Maps. Each heat map depicts a truck’s route over the course of a day. Delineated by the different colors, many trucks make trips back to the Fresno warehouse throughout the day to pick up additional deliveries.

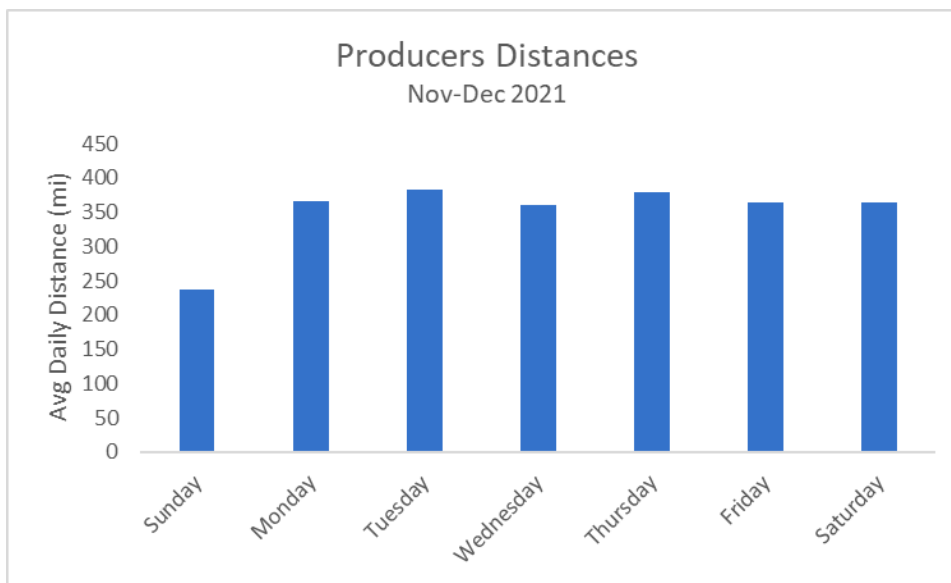

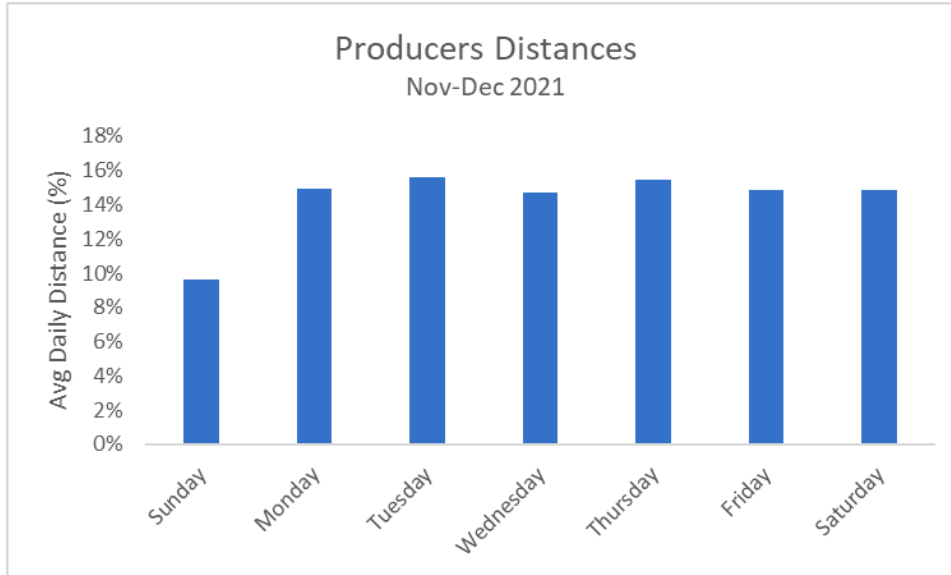

Average Daily Distances Traveled. The graphs above show the average daily distances traveled in November and December 2021. The top graph displays the distances in miles whereas the bottom graph shows the same distribution as a percentage.

5.10.3 RESTRICTIONS

Several project constraints affected the quality of analysis conducted. Since the load weight significantly affects the vehicle’s battery, the absence of trailer data is expected to affect route estimation accuracy.

With an expected delivery date in early February 2022, the data collection period for the electric trucks will be brief. The main concern is that findings from this data sample will be limited and not representative of the complete impact. Options for continuing to report data after grant close-out are being examined.

5.10.4 ANTICIPATED IMPACT

Like many other organizations, Producers Dairy is actively preparing for California’s requirement for medium- and heavy-duty trucks to be zero emission by 2045. In addition to being a partner on this initiative, Producers Dairy has been looking to purchase land adjacent to their current plant to not only expand operations but allow for additional charging spaces as their electric fleet grows. Fortunately, Producers Dairy owns their warehouse space which gives them flexibility in making on-site changes. As their space grows, they can also leverage their existing relationship with their local utility company. For organizations who do not own their site, getting approval from the property owner adds an additional layer of complexity on top of the already complicated utility and permits procurement process. Currently, chargers require a 9-month lead time for delivery. Considering additional delays, the initial EV adoption process is approximately 12 months from design to implementation.

Permitting is a known challenge for EV charging infrastructure programs. For this project in particular, the Authority Having Jurisdiction (AHJ) caused significant delay. The degree of readiness for permitting of high-power truck charging infrastructure varies greatly across the country. The City of Fresno took over four months to issue a

conditional permit for this project, which is exceptionally long. The permit is “at-risk,” meaning Fresno can still rescind permission to build, or add new tasks that must be completed to receive the official clear permit. Due to situations such as this, California has passed legislation (AB970) that limits the amount of time an AHJ can take to approve permits for EV charging infrastructure. The Producers Dairy project permit request was one month prior to that legislation taking effect in January 2022.

5.11 WORKFLOW CHANGES

With the adoption of two electric trucks, there are some modifications to the current workflow at Producers Dairy including changes to route assignments, truck inspections, as well as maintenance.

5.11.1 ROUTE ASSIGNMENT AND TRUCK MONITORING

The greatest hesitancy towards EV adoption is the limited driving range of current electric trucks. Producers Dairy has a variety of routes ranging in length, presenting an optimal opportunity to better understand the transition in a dynamic environment. Due to its 100-mile range, most of Producers Dairy’s daily routes will not be feasible with an electric truck. EV-appropriate, sub-100-mile routes have been identified during the initial data analysis phase. Routers will have to specifically assign these routes to the electric trucks to ensure that the deliveries can be executed.

In addition to route monitoring, the charge management software tool provides fleet managers and driver supervisors with real-time data on truck status. This will allow them to manage deliveries as well as communicate and assist drivers better. Projected charge levels and range estimation will help the routing team optimize routes for the next delivery.

5.11.2 PRE- AND POST-TRIP INSPECTIONS

With a much simpler drive train, the pre- and post-trip inspections for electric trucks are also expected to be much simpler. Drivers voiced frustration on the time-consuming nature of diesel truck inspections, but electric vehicle inspections will take significantly less time than their diesel units. Although most fluids are gone, drivers will still be required to examine areas such as tires and fault codes.

5.11.3 EV MAINTENANCE

Another significant anticipated impact is regarding EV maintenance. Preventative maintenance for electric trucks is not expected until after the first year of usage. However, the inspection will need to be completed at the dealer, rather than at in-house facilities or outsourced to vendors. This is because a technician must be certified to decommission the battery before work can be performed. A different technician is required to complete the actual inspection. OSHA (Occupational Safety and Health Administration) requires technicians to renew this certification annually.

Producers Dairy plans to set aside one of their six bays for EV-specific maintenance. Although they plan to train their technicians on EV maintenance, there is insufficient training available. In addition, in-house repairs may not be cost effective until they adopt more electric trucks into their fleet.

5.11.4 LEARNING CURVE

A learning curve is expected for drivers as well. While many diesel truck drivers have learned to economize fuel by minimizing braking, this is less of a concern in EVs. Due to the regenerative braking system in electric trucks, frequent stop-and-go driving does not use significantly more power than highway driving. Drivers will need to learn through experience how to maximize the range of EV's to gain confidence and reduce range anxiety.

5.12 FUTURE OUTLOOK

As with all new changes, it is expected that Producers Dairy will be conservative with initial route assignments. As confidence and familiarity grows, management will ease allowing for greater exploration of EV capabilities. The reduced inspection and maintenance requirements will be a welcome reprieve. Lastly, it is anticipated that this learning opportunity will provide meaningful insights needed to prepare for broader changes as the fleet adopts additional EV's in the future.

As of the due date for this report in early April 2022, the trucks are being tested and have not yet entered revenue service. As a result, there is no available data analysis or screen shots of the processed data in the software tool. The team will investigate the potential to provide post-project supplements when the trucks are in operation.

6.0 PROJECT SUMMARY ANALYSIS REQUESTS

Two areas of analysis were requested in relation to the ULTRA project:

1. Time spent in Disadvantaged Communities (DACs), and how much Zero-Emission operations occurred in DACs.
2. Estimation of jobs created as a result of the project

6.1 OPERATIONS IN DACS

An analysis of the mileage in ZEV mode by PHEV #3 through disadvantaged communities has been requested. That analysis requires mapping the routes and hybrid mode during revenue operations by IBT. That mapping would then be overlaid with the boundaries of DACs and the time within a DAC while in ZEV mode noted.

Because DAC boundaries were not initially considered in the development of the project and routing, it is possible that ZEV mode was not engaged when in DACs, although a fixed geofence could be programmed into the system. The design of the geofencing system for PHEV#3, as discussed above in the section on Electric Geofence, was intended to optimize electric operational efficiency. It dynamically identified areas where ZE mode could most easily be utilized. DAC boundaries were not directly used, instead the system used terrain, traffic, speed, and other factors.

Thanks to the work of Scott A. Epstein, Ph.D., a program supervisor in the air quality assessment group at South Coast AQMD, the following map has been created.

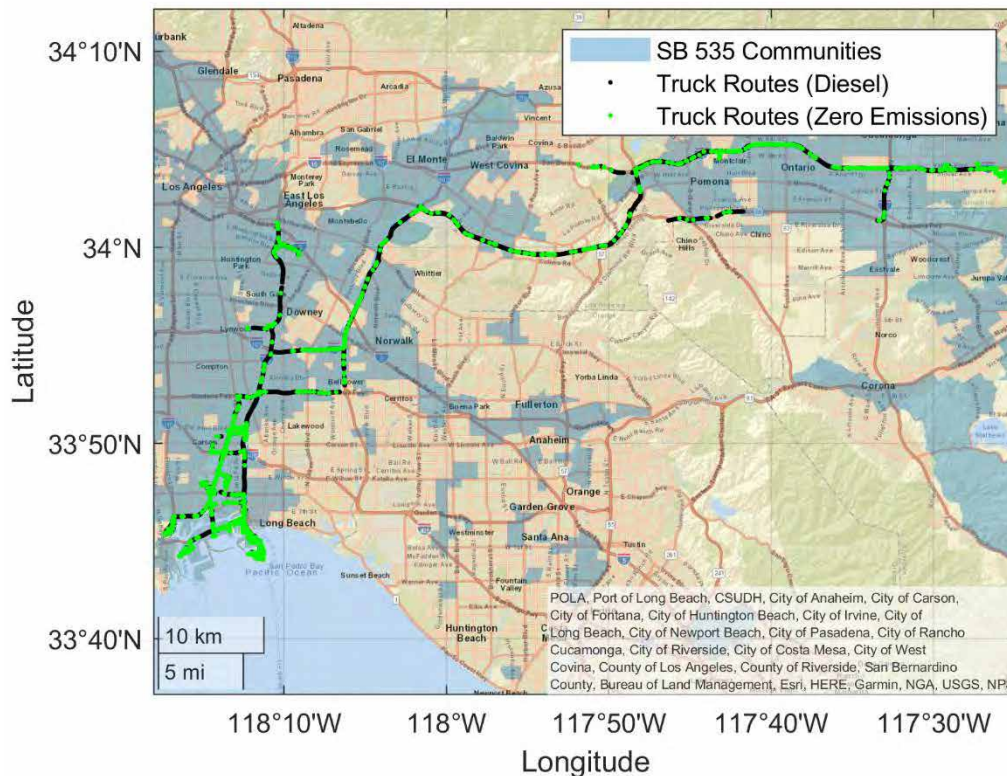

The overall finding was that 30% of the distance traveled and 49% of the time spent in Environmental Justice (EJ) communities as defined by SB535 was in zero emissions mode. These percentages would be greater, up to 100%, if DAC boundaries were added to the criteria for the XECU creation of Electric Zones. The potential for this technology to greatly reduce harmful emissions impacts on SB535 communities is clear, as is the need for increased use of fully zero-emission trucks.

6.2 JOB CREATION

The impact of this project on job creation is a factor of increasing importance and an analysis was requested. The ULTRA project is a bit unique as a technology development activity, which has mainly indirect effects on job creation.

Jobs Maintained

Approximately 20 positions within Volvo contributed to the project, and those roles would have been eliminated in economic constriction (layoffs) or transferred to other duties. Roles included: Mechanical and Electrical Engineers, Powertrain Engineers, Emissions System Engineers, Parts Designers, Technicians, Drivers, Program Managers and Software Engineers, plus multiple people in our metal shop and purchasing for parts creation, procurement, and delivery.

Outside of Volvo, the project supported at least 2 roles at UC Riverside, 2 roles at West Virginia University, and 3 roles at Tenneco or their consultants for the mini-burner EATS. There were also 2 roles at Ricardo, one at the Volvo dealership (TEC Equipment), and one at Motivo Engineering..

Net estimate is 30-35 jobs maintained as a result of the project itself.

Jobs Created

Knowing that the ULTRA project was the basis for the Volvo LIGHTS project and for the commercialization of Volvo BEV tractors, the job creation impact of the project is both far-reaching and difficult to estimate.

Volvo Trucks North America now has at least 8 roles in electromobility that did not previously exist, with posted openings for many more. Mack Trucks has added 3 such roles. Dealerships are adding electric truck sales specialists and technicians, and TEC Equipment has created an electrification leader position that is entirely new and unique among dealer groups. Customers are not yet adding positions directly as a result, but suppliers of electromobility services for customers are growing rapidly – companies like Freewire, Greenlots, Tritium, In-Charge Energy and others are increasing staff exponentially to serve the demand. Utilities are adding staff for infrastructure support and electric transport programs.





















Let us assume Volvo and Mack currently have 15 customers who are adopting electric trucks that were derived from work conducted under the ULTRA project. We can assume each of those customers creates jobs within Volvo and at supplier companies. If each customer creates 1 job within Volvo and 8 jobs within dealers, suppliers, and service providers, for a net estimate of 135 jobs created up to this point in time.

We can be certain ULTRA had an impact on job maintenance and creation. We estimate that during the 5-year period from 2017 to 2022 ULTRA influenced nearly 200 jobs. It is still very early in the transition to electric trucks and the impact will grow.

7.0 APPENDICES-ADDENDUMS

INTERIM REPORTS AND PUBLISHED PAPERS

THESE 19 REPORTS WILL BE PROVIDED AS SEPARATE FILES IN FOUR COMPRESSED FORMAT FOLDERS TO REDUCE FILE TRANSFER SIZE

-  5.2.4_Software in Loop Testing.docx
-  5.3.1 Study of EV Emissions Effects.docx
-  5.3.4 OBD Plan.pdf
-  5.3.5 Development of Emission Test Equipment and Procedure.docx
-  5.3.6 Low Temperature Conversion Efficiency Improvement_updated.pdf
-  5.3.7 Thermal Control Plan_updated.pdf
-  5.3.9 Emission Component Aging Plan.pdf
-  5.4.1 WP4-Task-2-Final-Report.docx
-  5.4.1 WP4-Task-2-Final-Report.pdf
-  5.4.3 Eco_Drive_Benefits Study_v2.pdf
-  5.4.4 Ecodrive_EmissionsImpact.docx
-  5.4.6 Eco-Drive implementation ITSC_paper_2019.pdf
-  5.4.8 PHEV #3 Demonstration Plan_revised.docx
-  5.4.9 Eco_Drive_CoSim_Report_Draft_r2.docx
-  5.7.1 Volvo - HD Class 8 Market Assessment_2-14-2018.pdf
-  5.7.2 Volvo - HD Class 8 Electrification Roadmap_3-5-2019.docx
-  5.7.3 Volvo - HD Low NOx Engine Assessment_2021 Update_6-3-2021 (Clean).docx
-  2021_ITSC_Truck EAD simulation study.pdf
-  PEMS Testing Results Summary (Volvo Sharing).xlsx
-  Volvo PEMS Testing Report [2022-02-14]_040522_revised.pdf